

MICHELIN

INFLATABLE SOLUTIONS

Defense

FARADAY ROOM

DESCRIPTION

The Faraday room is a Faraday cage designed to transform your open space into a secure meeting room.

This Michelin Inflation Solutions product allows you to isolate electromagnetic fields and protect you from communication networks, Wi-Fi, Bluetooth or to perform tests.

The faraday room is made from double-layer conductive materials with magnetic sealing of seams and openings.



High performance



Quick installation



Light



Compact

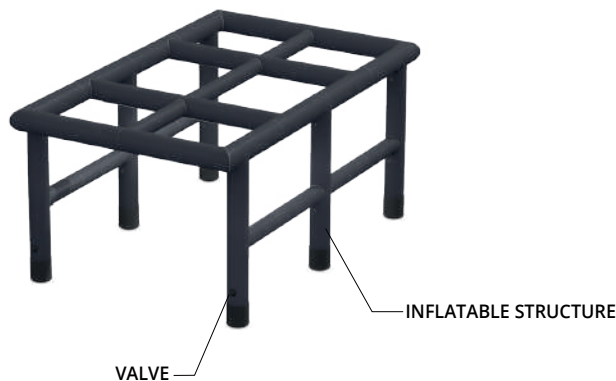

MICHELIN

ALL OUR PRODUCTS ARE DESIGNED AND MANUFACTURED IN FRANCE

TECHNICAL DATA

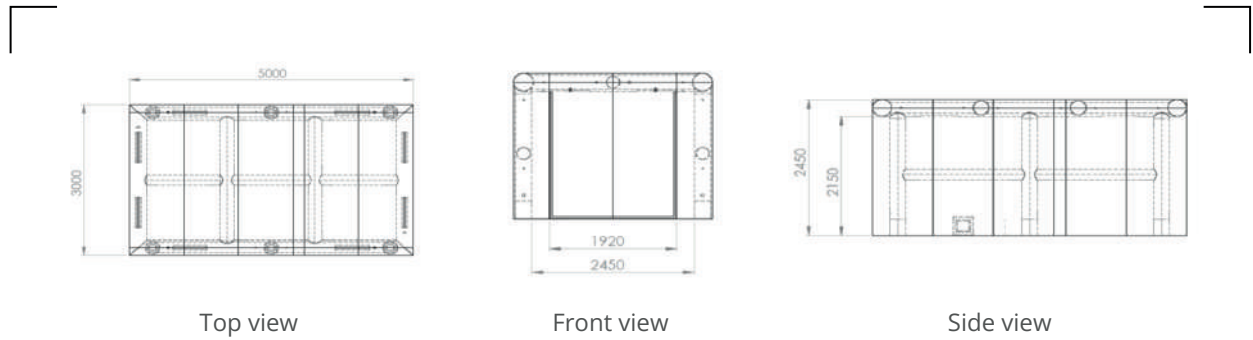

PERFORMANCE	Single layer 30 MHz to 10 GHz: 80 dBL
DIMENSIONS	5m x l 3m x H 2,45m
TOTAL WEIGHT	35 kg (with transport bag)
INSTALLATION TIME	10min (unfolding included)
EFLATION TIME	10min (folding included)
FOLDED DIMENSIONS	0,6m x 0,6m x 1m
MATERIALS	PU 100 micrometres, 600 denier fabric, EMC fabric with Velcro
COLOURS	Anthracite grey

Each order includes :

1 textile Faraday cage assembled on an inflatable frame - 1 electric pump -
1 transport bag - 1 repair kit

CONTACT

Because every project is unique, please contact our sales department to discuss and define your needs together.

Michelin Inflatable Solutions

5 avenue Jean Rostand
78190 TRAPPES
FRANCE

 commerce@inflatable.michelin.com
 <https://inflatable.michelin.com>

