



MECHANICAL CONCEPTS

Turn on bookmarks to navigate this document

PURPOSE OF THIS GUIDE

This “Study Guide” is designed to provide a review of basic Mechanical principles that are commonly used in industry. This Bearing types/symbols, Bearing categories, common lubrication methods and principles, and types of bearing failures.

Also included in the package is a review of common seals and gaskets, Gears, Belts and pulleys, Fasteners, Drawing and Blueprints and Precision measurements.



BEARINGS

BEARINGS AND THEIR CATEGORIES

Generalities

A bearing is a mechanical device and it is important to know its various components.

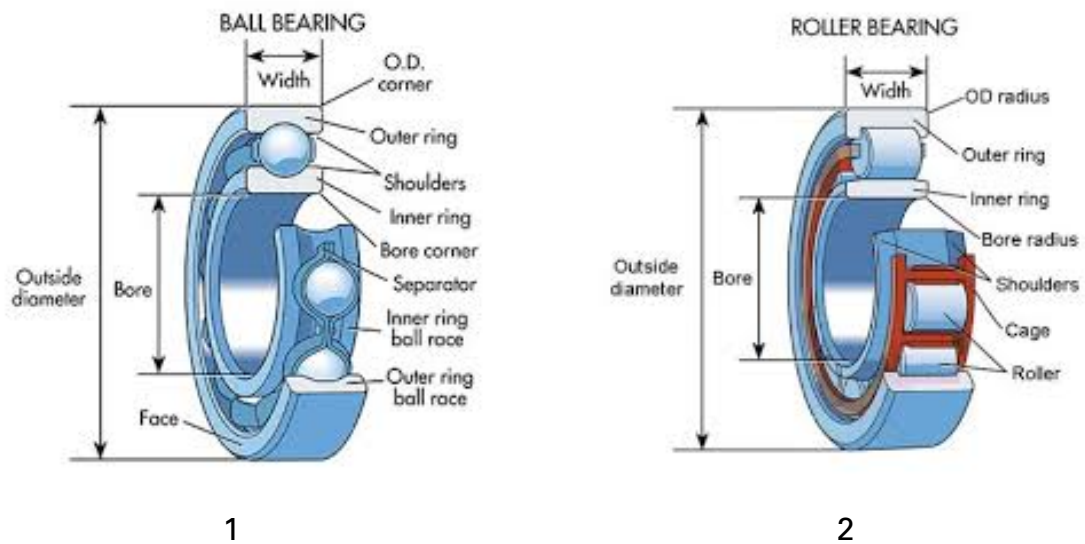

Figure 1-1

Categories of bearings

When in operation, a shaft is subject to axial and radial loads which tend to push it away from its axis center. There also can be combined loads which push it in both directions from its axis center. Manufacturers have grouped bearings under two headings based on axial and radial loads placed on the shaft. The two categories of bearing are radial bearings and axial bearings.

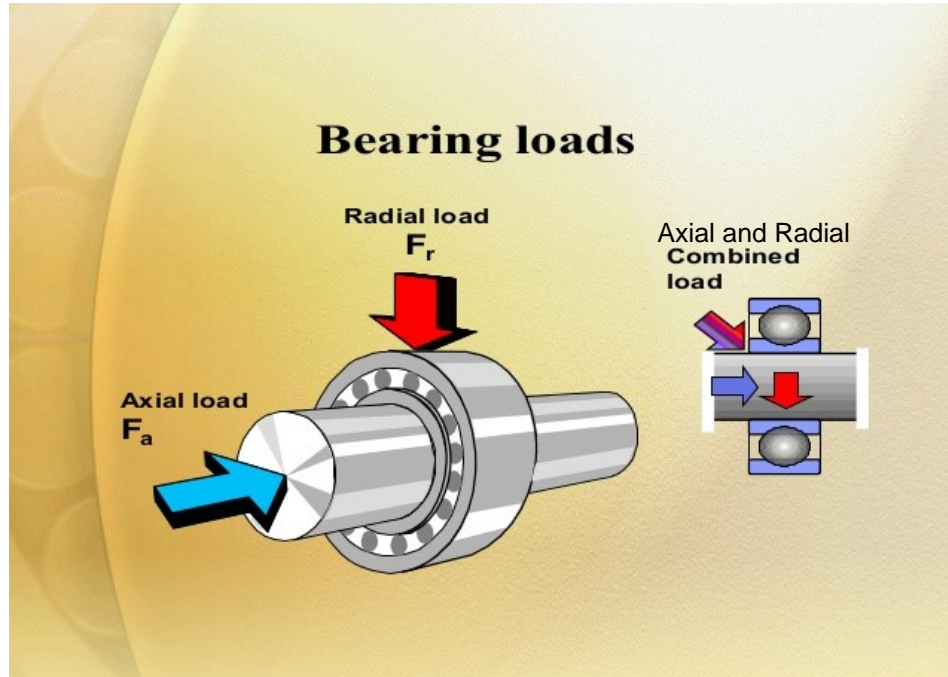

Figure 1-2

Radial bearings

Radial bearings are made with balls or rollers, depending on the how the bearings are used. They are designed to withstand forces that are perpendicular to the axis of the shaft.

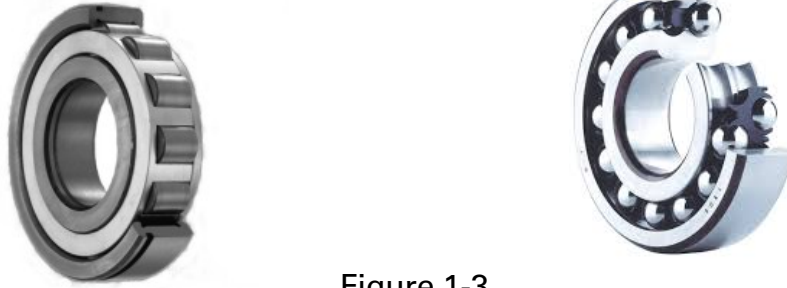

Figure 1-3

Axial bearings

Axial bearings, also known as thrust bearings, have either balls or rollers, but both are designed to withstand axial forces, which push or pull along the axis.



Figure 1-4

Radial bearings and their functions

Ball bearings



| Name | Function |
|-----------------------------------|---|
| Rigid, with balls and deep track. | Designed mainly to support radial loads, but can also take a bit of axial load. |

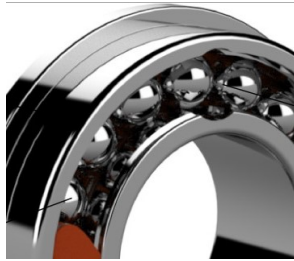

| Name | Function |
|------------------------------------|--|
| With filling notch. (Maxi-ball) | Designed to take a higher radial load than the bearing with deep tracks. However, the filling notch prevents the support of axial loads. |



| Name | Function |
|--|--|
| With deep tracks equipped with a shield. | The shield protects the interior of the bearing from dirt. |



| Name | Function |
|-------------------------|--|
| With two rows of balls. | These bearings have the same feature as the single-row bearings, but they can take heavy radial loads. |

Roller and needle bearings



| Name | Function |
|----------------------|---|
| Cylindrical rollers. | These bearings can withstand high radial loads and function at high speeds. |



| Name | Function |
|---------|---|
| Needle. | To take heavy radial loads and use less headroom. |

Thrust or axial bearings and their functions

Thrust ball bearings



| Name | Function |
|----------------------------|--|
| Single-effect ball thrust. | Designed to support axial loads in one direction. Does not support radial loads. |

Thrust cylindrical roller bearings



| Name | Function |
|----------------|---|
| Roller thrust. | Designed to support very high axial loads. Little sensitivity to shocks and space saving. |

Needle thrust bearings



| Name | Function |
|----------------|--|
| Needle thrust. | Support heavy axial loads, little sensitivity to shocks. Allow for fixed assembly and take little space axially. |

Double-row self-aligning ball bearing



| Name | Function |
|---|---|
| Self-aligning with double-row of balls. | Particularly suited to compensate for installation defects or shaft bending |

Spherical roller bearing



| Name | Function |
|--|--|
| Swivel-joint on rollers (self-aligning). | Designed to support heavy loads. Cope with alignment defect or shaft bending |

Angle-contact, dual-purpose bearings

Angle-contact bearings are designed to support radial and axial loads.

Dual-purpose ball bearings



| Name | Function |
|--|---|
| Single row angular contact ball bearing. | These single-row angle-contact bearings support axial loads in one direction only. Radial loads give rise to an induced axial stress. |



| Name | Function |
|---|---|
| Double row angular contact ball bearing | These double-row angle-contact bearings support axial loads in two directions. Radial loads give rise to an induced axial stress. |



| Name | Function |
|-------------------------------------|---|
| Dual-purposed with tapered rollers. | These single-row angle-contact bearings support radial and axial loads, but in one direction only. This type of bearing always supports the heavier of the two loads. |



BEARING LUBRICATION METHODS

Introduction to lubrication

The foremost purpose of lubrication is to create an intermediate coat between the parts sliding or rolling against one another, so that the friction and wear will be minimized as much as possible.

There are three types of lubricants:

- solid (powder);
- liquid (oil);
- semi-solid (grease).

Each has its own advantages and specific use.

Choice of lubricants

A properly lubricated bearing will not wear down because the lubricant will prevent the metal parts from touching thanks to a film of oil between the various moving components. When the manufacturer specifies a particular lubricant and a frequency of greasing, those instructions must be respected. Should the manufacturer not have specified anything, the following recommendations will prove useful.

In principle, all bearings can be lubricated either with grease or with oil. Ball thrust roller bearings are usually lubricated with oil, grease only being suitable for very low speeds. Bearings protected by flanges or joints have lifetime lubrication, that is they are filled with grease during manufacturing and then sealed.

The choice of lubricant is determined mainly by the operating temperature and the speed of rotation. Under normal operation, grease can generally be used. It sticks better to the assembly than oil and it also protects the bearing against humidity and impurities. Lubrication with oil is generally recommended where speed and temperature are high, when heat must be drawn away or when adjoining parts of the machine are lubricated with oil. The speed limits applicable to grease and oil are shown in the bearing charts.

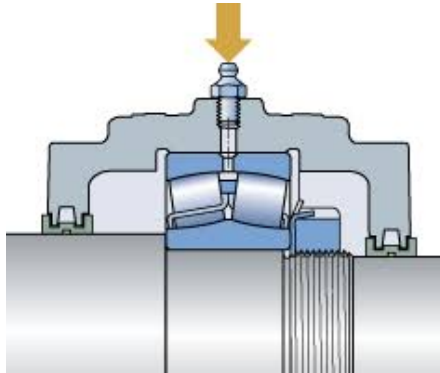

Figure 6-3
Injection greasing

Types of oil

Mineral oils refined with solvents are well suited for bearing lubrication. For temperatures greater than 125 C, synthetic oils, such as polyglycol, are recommended. Additives designed to improve various properties are usually necessary only if operations conditions are exceptional. Generally, an average or high viscosity index is preferred. However, when speeds are high one can use low viscosity oils to prevent an increase of temperature inside the bearing. Conversely, when the speeds are very low, high viscosity oils are mandatory to ensure the formation of a thick enough lubricating film.



MAIN CAUSES OF BEARING FAILURE AND STOPPAGES

Causes

Premature failure is generally caused by one or more of the following:

- contamination;
- distortion;
- misalignment;
- incorrect adjustment;
- incorrect lubrication;
- vibration when the bearing is not in motion;
- flow of an electric current through the bearing;
- poor maintenance practices.

Contamination

Contamination is defined as any foreign substance causing damage to the bearing. Humidity or an abrasive, such as sand or dust, will cause premature failure. Figure 7-1 shows scratches caused by grains of sand (a) and rust caused by humidity (b).

This kind of failure can be avoided by using the appropriate lubricant, by keeping the bearing clean during handling and by using seals that are clean and free of damage.



Contamination - Scratching



Contamination - Bruising (Denting)



**Figure 7-1
Contamination**

Distortion

When the shaft or the housing have been distorted, the bearing can wear out faster. If the shaft or the housing is no longer round, the rolling parts of the bearing will be subjected to extra pressure where the shaft or the housing is too large. This will cause cavities on the running surface. This problem can be solved by correcting the shaft or housing if neither can be repaired, the defective parts will have to be replaced.

**Figure 7-2
Distortion**



Misalignment

Misalignment can be caused by a shaft that has been twisted by shoulders that are not square, by a housing that is not parallel or by foreign objects caught between the bearing and its support. Figure 7-3 shows the classic consequence of misalignment: notice the path that the balls follow.

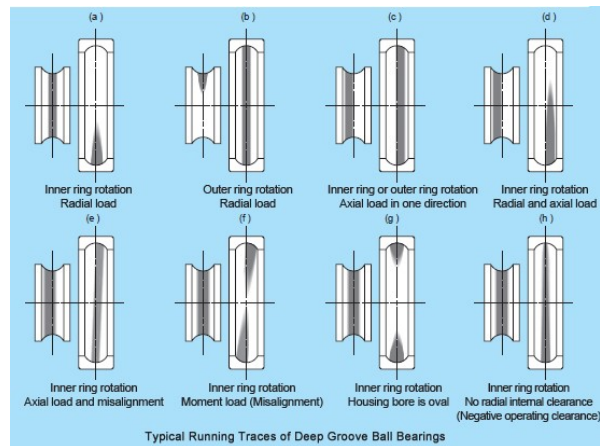

Figure 7-3
Misalignment

The cause of such misalignment must be determined and corrected, otherwise the same problem will appear with the new bearing.



-

Incorrect Fitment: The example shows that the inner ring is broken; this is the result of forcing a bearing onto a shaft that is too large.



Figure 7-4



Incorrect lubrication

Figure 7-5 (a) shows an example of smeared metal. This happens when the rolling components slide instead of roll, which stems from over- or under-lubrication. It is imperative to use the proper lubricant and to apply the appropriate amount.

Figure 7-5 (b) shows a rusted bearing, which happens when humidity enters the lubricant and causes the bearing to rust. Then the rust is mixed with the lubricant, which creates an abrasive compound.



(a)



(b)

Figure 7-5

Vibration in the absence of motion

Figure 7-6 shows a bearing damaged by vibrations while it was not in motion. This kind of stress will quickly break a bearing.

Wear caused by Vibration

- **Appearance**
Depressions in the raceways. These depressions are rectangular in roller bearings and circular in ball bearings. The bottom of these depressions may be bright or dull and oxidized.
- **Cause**
The bearing has been exposed to vibration while stationary.
- **Action**
Secure the bearing during transport by radial preloading. Provide a vibration-damping base. Where possible, use ball bearings instead of roller bearings. Employ oil bath lubrication, where possible.



Figure 7-6

Flow of an electric current through a bearing

When an electric current flows through a bearing in motion, it causes electric arcs. These, in turn, melt the metal, which leads to failure. Such electric currents are usually produced by electric arc welding where the ground goes through the bearing.

Damage due to Electric Current

- When an electric current passes through a bearing, i.e. proceeds from one ring to the other via the rolling elements, damage will occur. At the contact surfaces the process is similar to electric arc welding.
- **Appearance**
Dark brown or grey-black fluting (corrugation) or craters in raceways and rollers.
Balls have dark discoloration only. Sometimes zigzag burns in ball bearings raceways.
Localized burns in raceways and on rolling elements.
- **Cause**
Passage of electric current through rotating bearing.
Passage of electric current through non-rotating bearing
- **Actions**
Design electric circuits which prevent current flow through the bearings
Insulation of the bearing

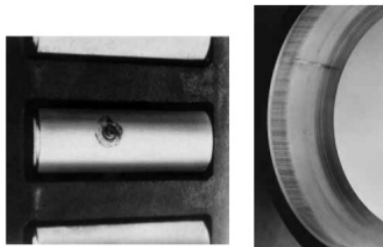

Figure 7-7



Poor maintenance practices

If improper practices are adopted when installing or removing a bearing, failures may occur.

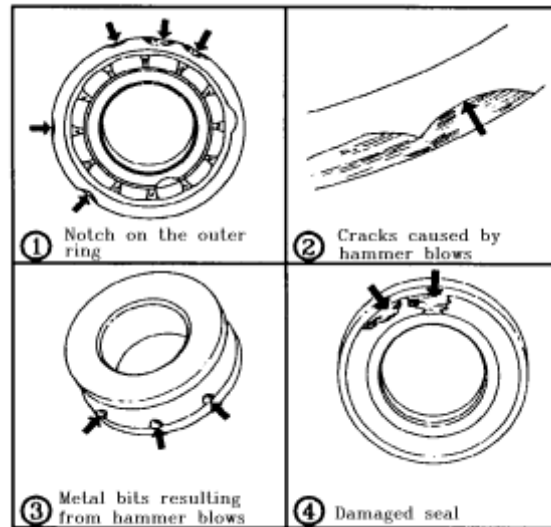
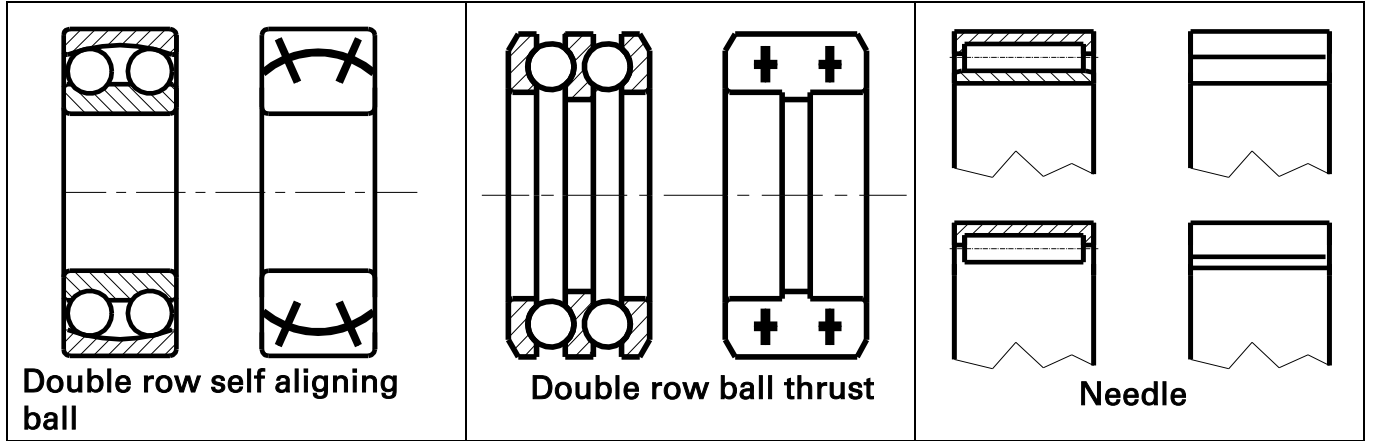

Figure 7-8
Incorrect practices

| | | |
|------------------------------------|---|----------------------------------|
| <p>Single row ball</p> | <p>Single row angular Contact ball</p> | <p>Tapered roller</p> |
| <p>Single row maxi ball</p> | <p>Double row angular contact ball</p> | <p>Spherical roller</p> |
| <p>Double row ball</p> | <p>Single row ball thrust</p> | <p>Cylindrical roller</p> |





LUBRICATION



PRINCIPLES OF LUBRICATION

Proper lubrication is essential to keeping industrial equipment operating. Almost every machine and tool requires lubrication to protect its moving parts and enhance operation. In almost any situation involving moving parts in a plant, lubricants will be involved.

WHAT IS LUBRICATION?

Lubrication is a means of separating moving surfaces under pressure. It is concerned with oils or other substances used to make surfaces slippery. To lubricate means to apply a lubricant, a substance which will provide a smooth, slippery film for moving parts to slide on.

WHY LUBRICATE?

There are six primary reasons for lubrication:

1. To reduce friction
2. To reduce wear
3. To help dampen shock
4. To cool moving elements
5. To prevent corrosion
6. To seal out dirt and other contaminants

Lubricants serve all six primary reasons for lubrication and fall into different classifications and types. The general classifications are :

- Liquid
- Semi-solid
- Solid
- Gas

The selection of a lubricant for any given application will be determined by the nature of the application itself. For example, bearings in a gear box are usually best lubricated by an oil, while bearings in a pillow block usually require a grease.



Types of Lubrication

Insufficient and excessive lubrication

Insufficient lubrication occurs when there is only enough oil to coat the two surfaces with a thin film, their rubbing against each other causes excessive wear, and ultimately breakage. Lets take the metallic surfaces shown in figure 1-11, but give them an insufficient amount of oil, so that instead of there being five planes of oil (A, B, C, D and E) there are only two (A and B).

The five-plane simplification was made to illustrate the fact that there is movement between planes inside the oil. A case of insufficient oiling occurs when this kind of motion is either hindered or not possible.

Excessive lubrication

On the other hand, excessive lubrication, particularly with grease rather than oil, prevents the proper dissipation of the heat created by the movement of the parts, for instance in a bearing. As heat rises in the bearing, so does the internal pressure, which will rupture the seals.

Proper lubrication

Proper lubrication means that there are enough planes of oil molecules sliding against one another to maintain oil friction, which completely separates the metal surfaces, under normal loads, and prevents the friction of solids.

Partial lubrication

Partial lubrication means that there are so few planes of molecules in the film that they break up and therefore cannot slide against one another any more. This occurs when the film is broken by the periodic touching of the contact surfaces. This condition will increase the heat inside the bearing, as if it was being subjected to twice its normal load.



Oil viscosity

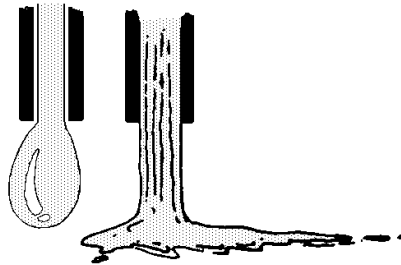

Figure 1-14

The degree of cohesion between the molecules of a given oil determines its viscosity. The more viscous an oil is, the more its molecules stick to one another.

Viscosity is the resistance to flow of a liquid at a given temperature.

Viscosity varies with temperature:

- the colder the oil, the thicker it becomes;
- the warmer the oil, the thinner it becomes.

Types of Seals

Static seals

Static seals are usually flat seals, but can be O-rings or sheet gaskets. The static joint neither moves nor is in contact with moving parts.

O-rings

The O-ring is the most widely used seal in farming or industrial hydraulic equipment. It is usually made of synthetic rubber and is used both for static parts and moving parts.





O-rings are designed to be positioned in grooves where they are compressed (about 10%) between two surfaces in the case of static applications.

When they are subject to very high pressure they are reinforced by back up rings to prevent the O-rings expulsion from the groove therefore causing leaks. Back up rings are usually made of fiber, leather, plastic or synthetic rubber.

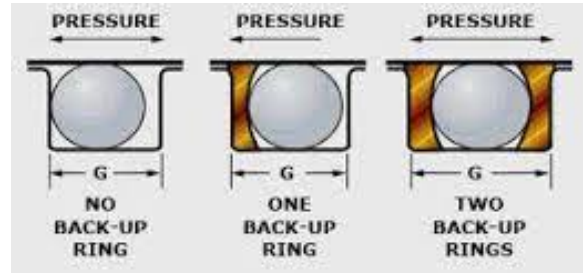

Flat seals or sheet gaskets

Obviously, flat seals can only be used in static assemblies. Their sealing properties depend on their ability to mold themselves to the imperfections that exist on the faces of the joint. Proper sealing depends on this feature. Such seals are made of various substances. Some are metallic, and have no specific shape.





Dynamic seals

Dynamic seals are either moving or subject to motion. They include seals for shafts, piston rods and packings. In the latter case, some oozing is necessary to ensure lubrication. There are a number of types of seals, of which O-rings, "V" or "U" packing, spring-loaded lip seals, metal-to-metal seal and packings.

O-rings

When O-rings are used on moving parts, they should be in contact with very smooth surfaces. They cannot be used if this entails straddling an opening or where angles are under pressure. Nor should they be installed on rotating shafts because of wear problems.

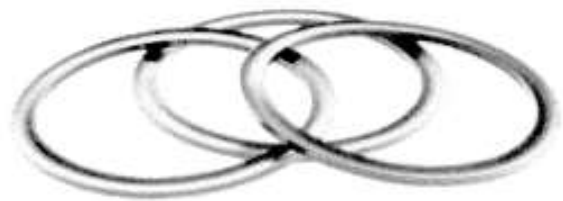

When there is longitudinal movement and pressures are high, support rings are used to prevent the deformation of the O-ring.

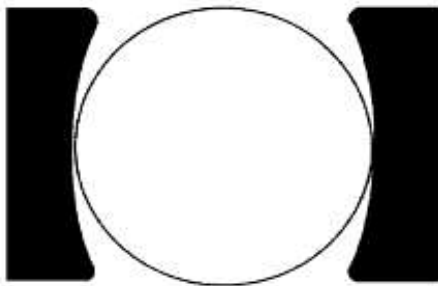

O-ring with support rings

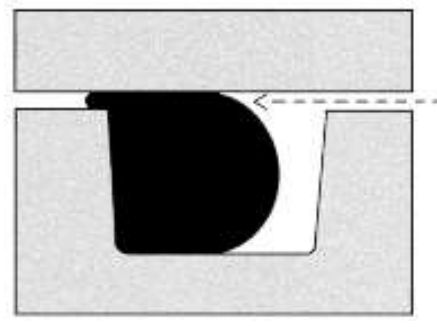

Dynamic O-ring deformed by pressure

"V" and "U" packing

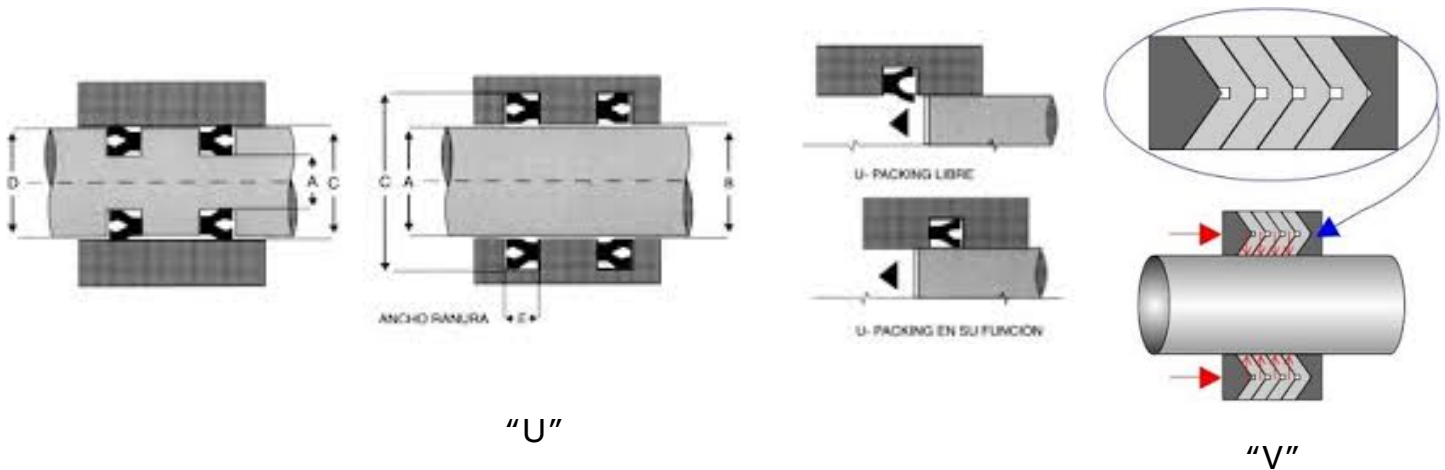

"V" and "U" packings are used to ensure water-tightness of mechanical components which have a longitudinal motion, such as piston cylinders, jack screws. They are usually made of leather, natural or synthetic rubber, plastic and other materials. These packings must be installed with the concave side, or lip, facing that part of the system that is under pressure. The pressure will force the lip against its mating part, thus ensuring a good seal. Such packing can comprise a number of "V" or "U" shaped rings to make a homogeneous packing held tightly in a packing assembly or stuffing box.

Spring-loaded lip seals

These seals are an improvement over the common "V" or "U" packings. The lip of the seal is covered by a spring which forces it against the part's complementary surface. Generally, this seal is equipped with a metallic envelope which fits into a hole in the housing to which it is affixed. This type of seal is often used to ensure the tightness of moving shafts. The lip of the seal normally faces the liquid containing side. Sometimes, double-lip seals are used to provide a seal in both directions.

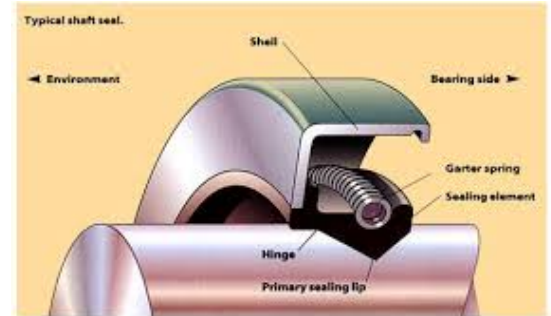

Spring Loaded Lip Seal

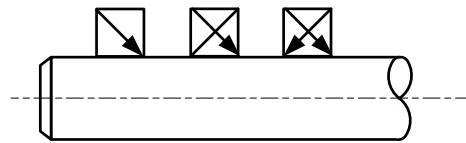

Drawing Symbols for Lip seal

The above figure shows the drawing symbols for a Single Lip Seal, a Single Lip Seal with Anti Dirt Lip (sometime referred to as a double lip seal), and a Double Lip Seal.

Metal-to-metal seals (metallic segments)

Metal-to-metal seals used for pistons and piston rods are similar to piston segments found in motors. They may or may not be extensible. They are used on moving parts and are usually made of steel. Unless their adjustment is very tight, non-extensible seals will leak too much. Extensible seals (used in pistons) and packings (used for piston rods) create some friction and are subject to small amounts of leakage.



Metallic Seal



Packings

Packings found in stuffing boxes are used for moving parts. They are made of plastic, asbestos, cotton, rubber, malleable metals or alloys, or a combination of some of the above. Packings are often used in the same way as "V" or "U" packings. They are sold in rolls or pre-cut spiral segments of standard sizes. They are used to provide tightness under low pressures only. It is very important that such packings be properly lubricated, otherwise they may scratch or wear moving parts, lead to overheating and diminish tightness.

Packing



Dynamic seals (labyrinth)

Dynamic seals (labyrinth) are used to isolate bearings completely by holding the lubricant in and keeping out any outside contaminants, such as dust, water, steam, corrosive gases, etc. There is no friction between dynamic seals and a shaft or with other internal parts. Therefore no wear of either the seal or the shaft. Dynamic (labyrinth) seals comprise a stator and a rotor. The stator is pressed into the bearing housing and an O-ring ensures extra tightness. There is some play between the stator and the shaft. The shape of the labyrinth keeps the lubricant inside the housing. The shaft drives the rotor through the action of one or more O-rings. The rotor fits inside the stator which creates a labyrinth. This labyrinth prevents penetration of contaminants. Because of the back-up motion caused by the grooves in the labyrinth seal, there is always some play (about 0.05 mm) between the rotor and the stator; therefore there is no mechanical contact.

Contaminants that get into the assembly lose their kinetic energy inside the labyrinth and are channeled into a ring groove. From there, they are ejected and exit the seal by gravity through an opening. This is caused by the particular shape of the rotor.

Generally, the stator is made of Teflon-coated brass, whereas the rotor is made of stainless steel. There are, however, other combinations of materials. The following figure shows a typical Labyrinth seal installation.





BELTS AND PULLEYS



CATEGORIES OF BELTS AND PULLEYS

Belt drive

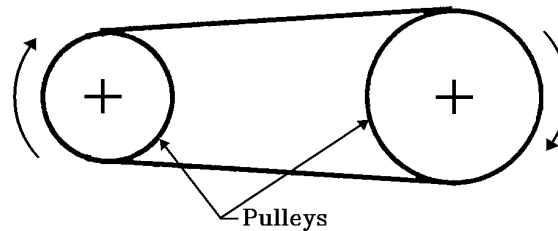

Figure 1-1
Set of pulleys and belt

The pulley-belt system is one of the most ancient means of power transmission. At first, the belt was made of rope and the pulleys were made of wood. Today's belts and pulleys are vastly different and made to fit modern equipment requirements.

The basic principle of the belt system is that the transfer of energy is achieved through the friction between the pulley and the belt. This friction is obtained by keeping the belt under tension.

Advantages and disadvantages of a belt drive

Belt drives are used extensively in industrial processes. However, this type of transmission must be selected after careful analysis of its advantages and disadvantages.

Advantages:

- shock absorption of sudden changes;
- durability;
- ease of installation and maintenance;

- flexibility;
- allowance for variations in speed;
- relatively cheap;
- silent operation;
- no lubrication.

Disadvantages:

- heat generation;
- frequent adjustments needed;
- slip;
- lengthening of the belt;
- rapid wear when improperly positioned.

NOTE: Though belts resist heat, oil and grease quite well, it is best to check with the manufacturer as to compatibility.

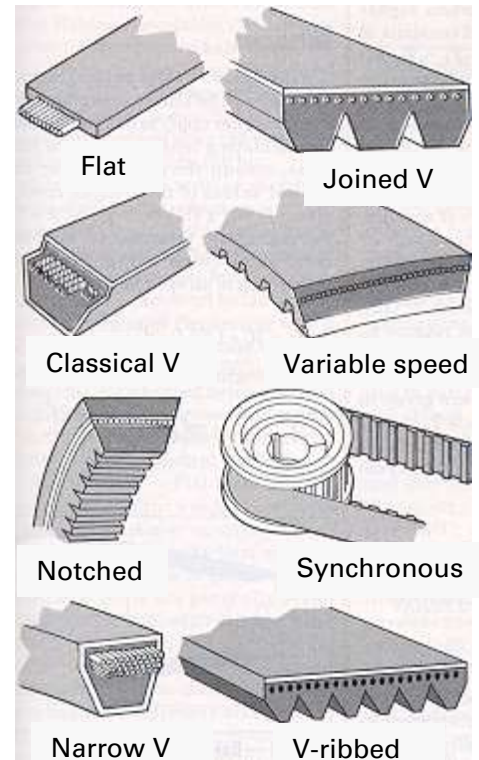

These various points are the basis for determining when it is best to use belt-drive devices. They are used, for instance, when:

- the distance between centers is too great for a chain or a gear mechanism;
- slip does not matter much;
- silent and flexible transmission is indicated.



PRINCIPLES OF BELT DRIVES

Speed-transmission ratio

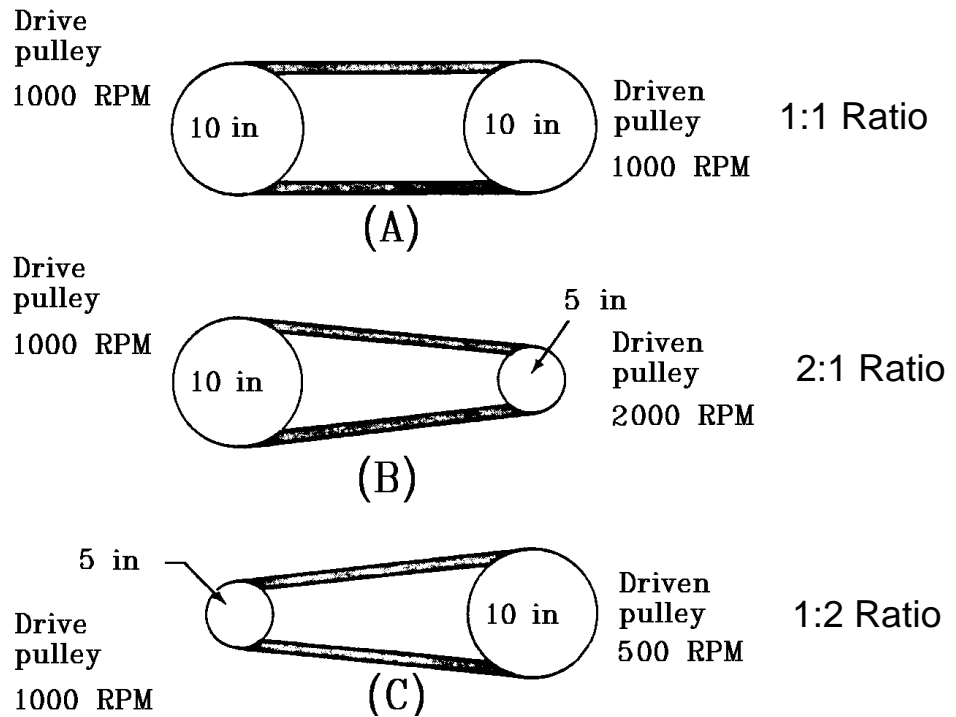

Figure 2-1
Speed ratios

The speed of the driven pulley is governed by two factors:

- the speed of the drive pulley;
- the ratio between the driven pulley and the drive pulley.

NOTE: Slip can also have an effect of the speed of the driven pulley.



Figure 2-1 shows that when pulleys are of equal size (A), they turn at the same speed; when the driven pulley is smaller (B), its speed will be greater than that of the drive pulley; if the drive pulley is smaller (C), the speed of the driven pulley will be slower.

There is a simple formula that gives the speed of the driven pulley when the speed of the drive pulley is known.

$$\frac{\text{INPUT RPM}}{\text{OUTPUT RPM}} = \frac{\text{OUTPUT DIA.}}{\text{INPUT DIA.}}$$

Note: number of teeth, radii, or circumferences can be substituted for the diameters

By cross multiplying, you can solve for the output rpm :

$$\text{OUTPUT RPM} = \frac{\text{INPUT RPM} \times \text{INPUT DIA.}}{\text{OUTPUT DIA.}}$$

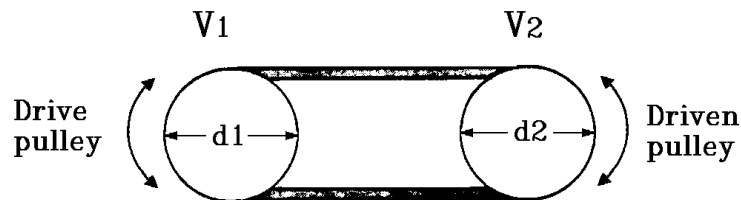

Figure 2-2
Calculation diagram



Example

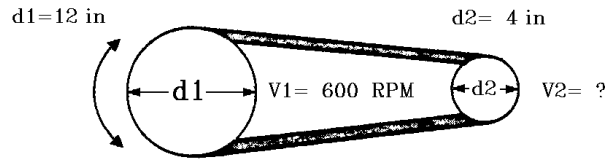

Figure 2-3
Example of calculation

$$\begin{aligned} \text{OUTPUT RPM} &= \frac{\text{INPUT RPM} \times \text{INPUT DIA.}}{\text{OUTPUT DIA.}} \\ &= \frac{600 \times 12}{4} \\ &= \frac{7200}{4} \\ &= 1800 \text{ RPM} \end{aligned}$$



Aligning sprockets and pulleys

There are many similarities when aligning sprockets and pulleys.

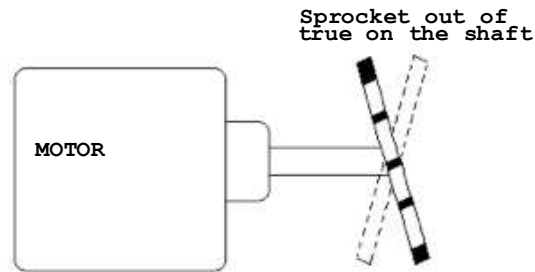

Example of a sprocket out of true or wobble on the shaft

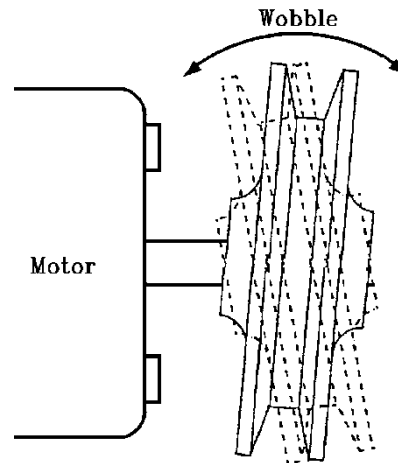

Example of a pulley out of true or wobble on the shaft

Before starting to align two sprockets or pulleys, it is important to check that they are not buckled or running out of true. The drive component can be checked using a dial indicator gauge with a magnetic base. The magnetic base is attached to a solid part of the system frame and the gauge button is placed against the outside of the sprocket or pulley on the flat part near the edge. The gauge reading is noted and the component is then turned slowly. If there is a noticeable variation in the gauge reading, the sprocket/pulley is either wobbling or running out of true on the shaft. A sprocket/pulley running out of true must be removed and, if possible, re-positioned correctly on the shaft.



A sprocket/pulley will be out of true if it is not positioned properly on the shaft, if the press screw for the key is too loose or too tight, or if the bolts fixing it to the shaft are not correctly tightened. The sprocket/pulley itself may be deformed (buckled or warped) as the result of damage or because it was not turned and milled correctly during manufacture. It is possible to adjust the bolts and key but, if the sprocket/pulley deformed, it must be replaced.

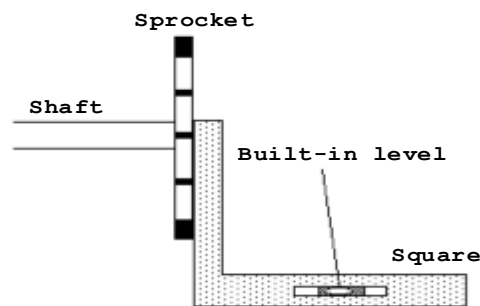

Use of a square with a built-in level to check the verticality of a sprocket/pulley

The last step in the preparation for the alignment procedure is to check the verticality of the two sprockets/pulleys relative to the same level of reference. The level of reference is usually the floor on which the machine is standing. The sprockets/pulleys are checked one at a time. When the level of reference is the same, the verticality of each one can be checked with an ordinary square. When the level of reference is different, a square with a built-in level must be used. If the sprockets/pulleys are not vertical to the reference level, shims should be placed under the motor frame, or under the support bearing frame (depending on which way the shaft needs to be tilted) and added to until they are vertical.

Another way of checking the verticality of a sprocket is to place a level against the flat surface of the sprocket/pulley. If the position of the bubble indicates it is not vertical, the shimming method described in the previous paragraph can be used to adjust it.

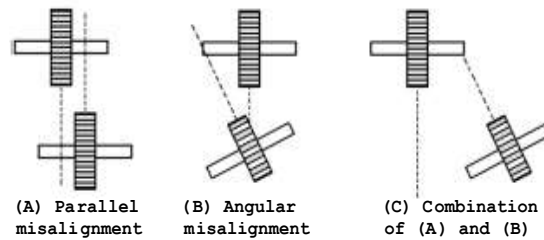

Recognizing the type of misalignment right from the beginning makes aligning the components easier and eliminates the need to carry out further work to "correct" misalignment. Types of sprocket/pulley misalignment are shown above.

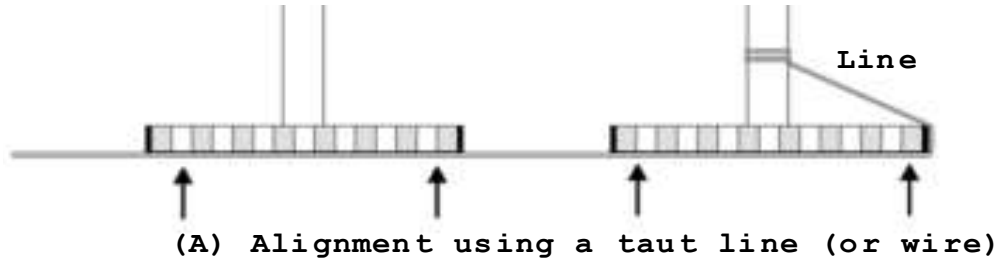

There are several methods for aligning sprockets. However, two methods are generally used in industry. The first is used if the sprockets/pulleys are too far apart for a straight edge to be used. It involves stringing a taut line or a length of piano wire between the two sprockets. The sprockets/pulleys are properly aligned if the line just touches the flat surfaces of the components at the four points indicated with arrows. If the line does not touch at all four points, one or both will need to be moved. This adjustment is done usually by means of jackscrews or built-in adjustment bolts. Once the adjustments are made, the alignment should be rechecked.



The second method involves the use of a straight edge, which is placed against the flat part of each sprocket. The straight edge should just touch the same four points indicated by the arrows in figure above.

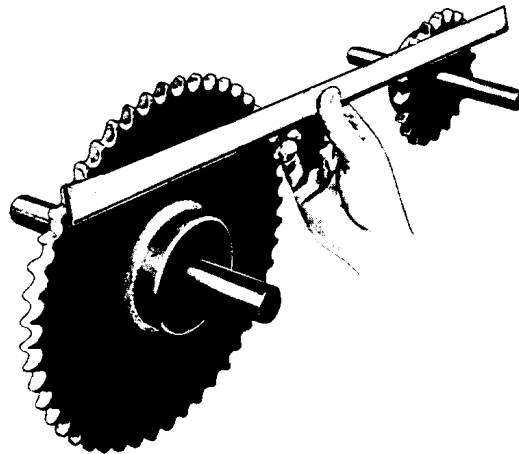

You may check the four points of contact with a feeler gage at the contact points. For V-belt drives $1/10$ inch per foot of pulley distance is the maximum gap the feeler gage should measure. (Distance is measured from outside of one pulley to the outside of the other pulley.) For Synchronous and V-ribbed belts $1/16$ inch per foot of distance is the maximum gap the feeler gage should measure. A Chain drive's maximum gap should measure less than $1/32$ inch per foot of distance.

What would be the gap measured with a feeler gage at four points of contact for a V-belt where the distance from outside to outside of the pulleys is 3 ft. 6 in.?



GEARS

Gear Types



Spur



Helical



Herringbone



Plain Bevel



Spiral Bevel



Hypoid



Worm and Wheel



Rack and Pinion



Internal

TYPES OF GEAR DRIVES

There are two types of gear drives: open or boxed.



TYPES OF GEAR DRIVES

There are two types of gear drives: open or boxed.

In an open drive, the gear assembly is not contained in a housing. Examples are found on paper machines and printing presses where rollers are set into motion, or in machines where a rack transforms a rotative movement into an alternative movement.

This type of drive is secured at each shaft by bearings and is normally designed with large gears for low-speed work.

In a boxed drive the gears are enclosed in a housing and can not be seen. An example of this would be a automotive manual transmission.



Open gear drive



Boxed gear drive

Gear Nomenclature

The following chart list the basic terminology associated with spur gears.

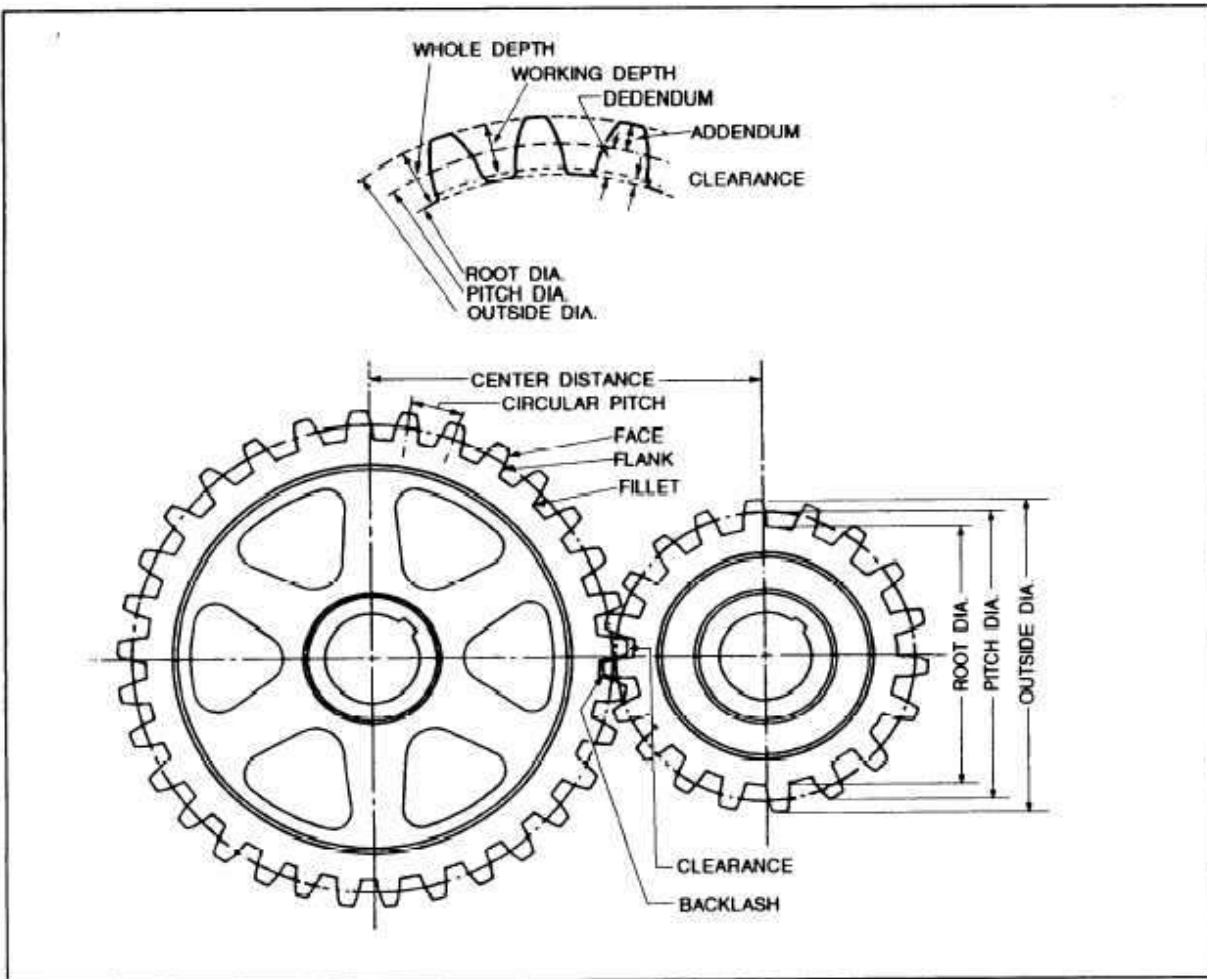



Backlash

Backlash in gears is the play between teeth that prevents binding. In terms of tooth dimensions, it is the amount by which the width of tooth spaces exceeds the thickness of the mating gear teeth. Backlash may also be described as the distance, measured along the pitch line that a gear will move when engaged with another gear that is fixed or immovable.

Normally there must be some backlash present in gear drives to provide running clearance. This is necessary as binding of mating gears can result in heat generation, noise, abnormal wear, possible overload, and/or failure of the drive. A small amount of backlash is also desirable because of the dimensional variations involved in practical manufacturing tolerances.

Backlash is built into standard gears during manufacture by cutting the gear teeth thinner than normal by an amount equal to one-half the required figure. When two gears made in this manner are run together, at standard center distance, their allowances combine, providing the full amount of backlash required.

On non-reversing drives or drives with continuous load in one direction, the increase in backlash that results from tooth wear does not adversely affect operation. However, on reversing drives and drives where timing is critical, excessive backlash usually cannot be tolerated.

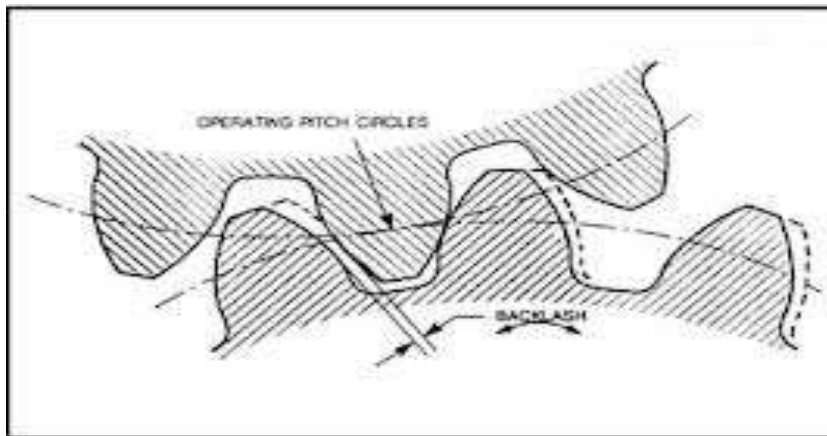

Figure 1



Types of gears used:

- spur gears,



Figure 1-3

- helical gears,



Figure 1-4

- herringbone gears,





Right-angle gear drives

The shafts of these drives are positioned at right angle to each other, usually in the same plane. The teeth are straight or spiral, or hypoid (when the shafts are not in the same plane).



In the case of the beveled spiral gears, one extremity of a tooth engages into the gear before the preceding one disengages. As with spiral gears, energy transmission is effected smoothly. A spiral gear set comprises one gear angled to the right, and one to the left.

Angular beveled gears are mounted on shafts that usually make a 90° angle.

Bevelled gears produce radial thrust as well as axial thrust; it is recommended to use bearings or thrust collars behind the gears to support the thrust.



Worm gears



Figure 1-9

This gear drive is made of an endless screw which drives a gear whose teeth are contoured to fit properly in the thread of the screw.



FASTENERS

THE PRINCIPAL INDUSTRIAL FASTENERS AND THEIR USES

Threaded components

Bolts

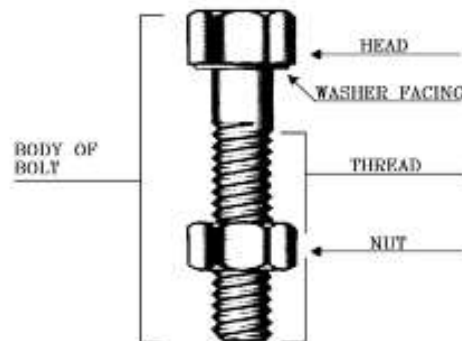

A bolt is an assembly component consisting of a rod, with a thread on one end a head on the other, which is used with or without a nut to join two objects together. The union is not permanent, that is, the objects can be easily separated again without being damaged.

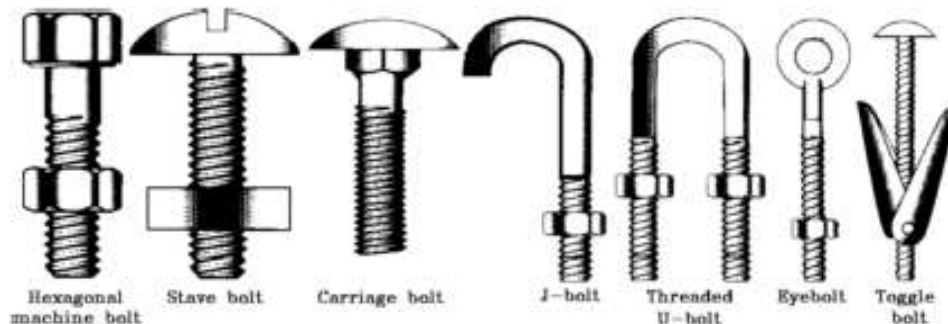

The principal types of bolts used in industry are shown in Figure 1-2. Joining parts of something tightly together with bolts is easy and economical. Generally speaking, the word "bolt" is understood to mean "machine bolt" because it is the type most commonly used. However, there are a number of different types which can be distinguished according to the material they are made of, the shapes of their heads, and their threads.

Threads

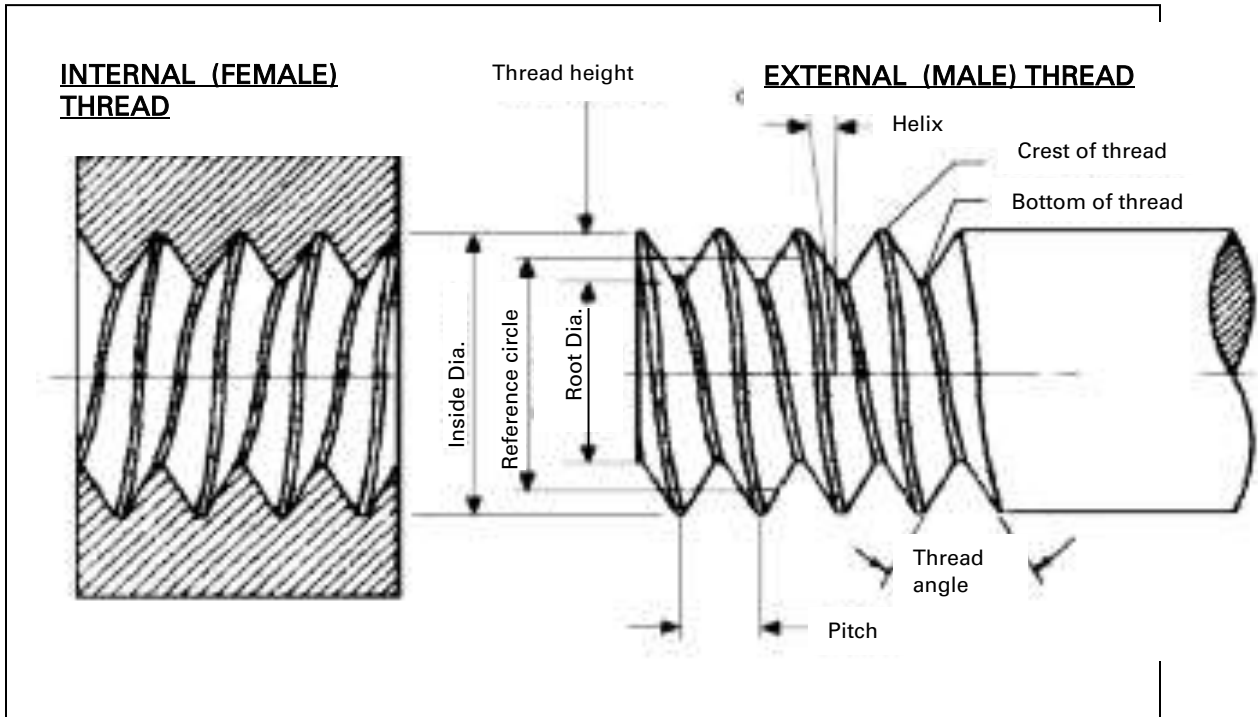
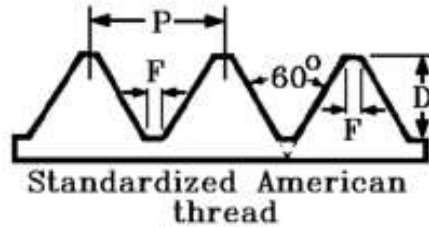

Figure 1-3
The parts of an inside and an outside thread

Threads are regularly shaped helical (spiral) ridges cut into the inside surface of a hollow cylinder or the outside surface of a solid cylinder. The cylinder may be straight-sided or conical. Threads are classified according to their basic dimensions: **pitch** (the distance between two consecutive ridges) and **indicated diameter**, both given in metric units. In the British system, the identifying measurements are different: the number of threads per inch, plus the length and the indicated diameter of the bolt (or screw). In industry, most threads are right-handed which means the bolt or screw is tightened by turning it (or the nut) in a clockwise direction. Some bolts and screws, however, have left-handed threads.



Types of threads



$$D = 0.6495 \times P \text{ or } \frac{0.6495}{N}$$

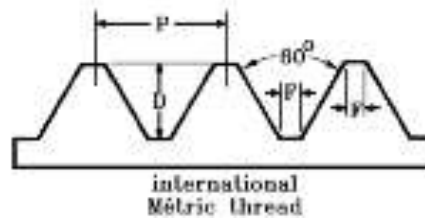

$$D = 0.7035P$$

(maximum)
= 0.6855P (minimum)

where:

D = thread height (or depth) P = pitch

N = number of threads per inch

C = root width (the width of the flat part at the bottom of the thread).

The values of the outside (or major) diameter and the thread angle are usually given values.



**COMBINATIONS OF DIAMETER
AND ISO METRIC PITCH**

| Indicated diameter (mm) | Pitch of thread (mm) | Indicated diameter (mm) | Pitch of thread (mm) |
|-------------------------|----------------------|-------------------------|----------------------|
| 1.6 | 0.35 | 20 | 2.5 |
| 2 | 0.40 | 24 | 3.0 |
| 2.5 | 0.45 | 30 | 3.5 |
| 3 | 0.50 | 36 | 4.0 |
| 3.5 | 0.60 | 42 | 4.5 |
| 4 | 0.70 | 48 | 5.0 |
| 5 | 0.80 | 56 | 5.5 |
| 6 | 1.00 | 64 | 6.0 |
| 8 | 1.25 | 72 | 6.0 |
| 10 | 1.50 | 80 | 6.0 |
| 12 | 1.75 | 90 | 6.0 |
| 14 | 2.00 | 100 | 6.0 |
| 16 | 2.00 | | |

**COMBINATIONS OF DIAMETERS AND
NUMBER OF THREADS PER INCH**

| Size No. or inches | Threads per inch | Indicated diameter (inches) | Size (in.) | Threads per inch | Indicated diameter (inches) |
|--------------------|------------------|-----------------------------|------------|------------------|-----------------------------|
| #4 | 40 | 0.1120 | 9/16 | 12 | 0.5625 |
| #4 | 48 | 0.1120 | 9/16 | 18 | 0.5625 |
| #6 | 32 | 0.1380 | 5/8 | 11 | 0.6250 |
| #6 | 40 | 0.1380 | 5/8 | 18 | 0.6250 |
| #8 | 32 | 0.1640 | 3/4 | 10 | 0.7500 |
| #8 | 36 | 0.1640 | 3/4 | 16 | 0.7500 |
| #10 | 24 | 0.1900 | 7/8 | 9 | 0.8750 |
| #10 | 32 | 0.1900 | 7/8 | 14 | 0.8750 |
| 1/4 | 20 | 0.2500 | 1 | 8 | 1.000 |
| 1/4 | 28 | 0.2500 | 1 | 12 | 1.000 |
| 5/16 | 18 | 0.3125 | 1 1/8 | 7 | 1.1250 |
| 5/16 | 24 | 0.3125 | 1 1/8 | 12 | 1.1250 |
| 3/8 | 16 | 0.3750 | 1 1/4 | 7 | 1.2500 |
| 3/8 | 24 | 0.3750 | 1 1/4 | 12 | 1.2500 |
| 7/16 | 14 | 0.4375 | 1 3/8 | 6 | 1.3750 |
| 7/16 | 20 | 0.4375 | 1 3/8 | 12 | 1.3750 |
| 1/2 | 13 | 0.5000 | 1 1/2 | 6 | 1.5000 |
| 1/2 | 20 | 0.5000 | 1 1/2 | 12 | 1.5000 |

Nuts



Basic design of a nut

Nuts are hollow threaded metal blocks or threaded rings which are used with bolts to make up a complete fastener. They are usually made of the same metal as the matching bolt and have the same size thread.

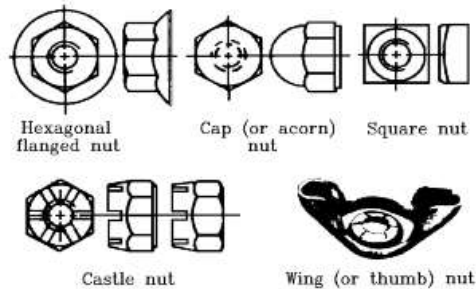

Various types of nuts

Various types of nuts used in industry are shown in Figure 1-11.

Screws



A typical self-tapping metal screw

A screw is a fastener made of a metal rod which is threaded at one end and has a slotted head at the other. Unlike bolts, screws do not require nuts to complete the fastening. They are used alone to join metal or wooden parts together temporarily or permanently. Parts joined with screws can be easily taken apart again without being damaged, whereas parts joined with rivets cannot (unless the rivets are drilled out). There are two basic types of screws: wood screws, used for joining pieces of wood, and metal screws, used for joining pieces of metal. Wood screws can usually "tap" (make threads in) pilot holes drilled in the wood. Regular metal screws, which look like bolts, will only screw into threaded (that is, pre-tapped) holes in

the metal. However, self-tapping metal screws can tap a thread in pilot holes made in the metal.

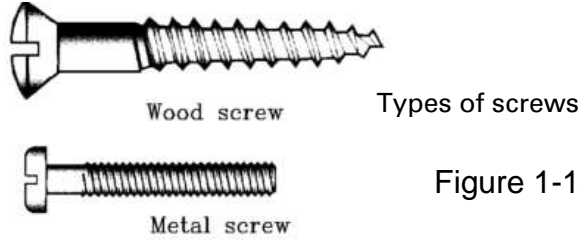

Screws are further subdivided according to the type of slot in the screw head. The common slots are shown in Figure 1-14. Each requires a different type of screwdriver.



Figure 1-14
Different types of screw head slots

Keys

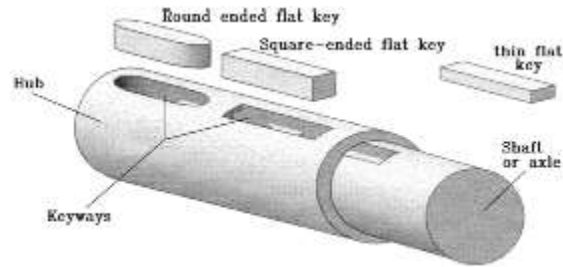
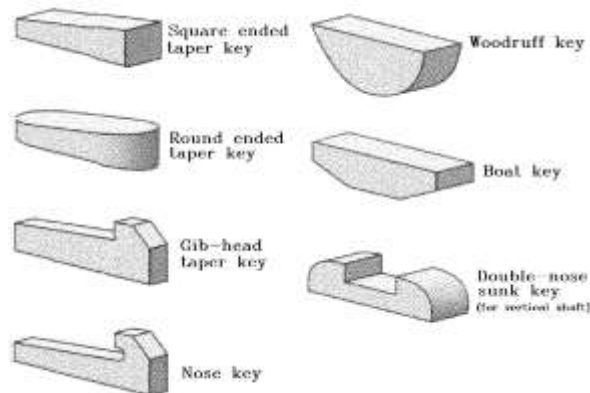

Figure 1-15
Parallel (flat) keys

A key is a fastening device used to attach the hub of a pulley, a gear wheel or a coupling to a shaft. The key is placed in the slot cut in the shaft and the corresponding slot cut in the hub of the pulley, gear wheel or coupling. It joins the two parts together so that any rotary force is transmitted to both of them. The key can also function as a "safety linkage" as it will break if the shear force becomes excessive; this feature could prevent more serious damage to the system.

NOTE: Ordinary handles, crank handles and all components which rotate on a shaft can be keyed.



Other types of keys

Pins

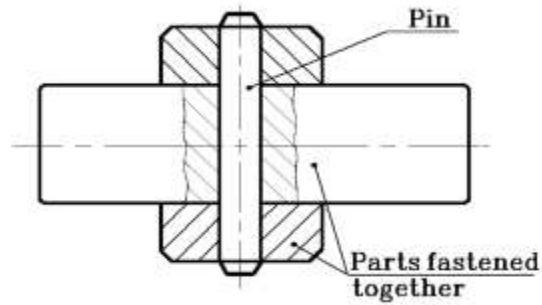

Pins are devices made of metal or other material which are used to fasten parts with holes specially bored in them to take the pin. A pin can also be used to establish the relative positions of the parts or to join and immobilize them. There are two basic types of pins:

- detachable or removable pins which are usually left in place;
- special removable pins which are used when rapid assembly and disassembly of parts is desired. These pins are inserted and removed frequently.

Pins which are removable but are usually semi-permanently installed

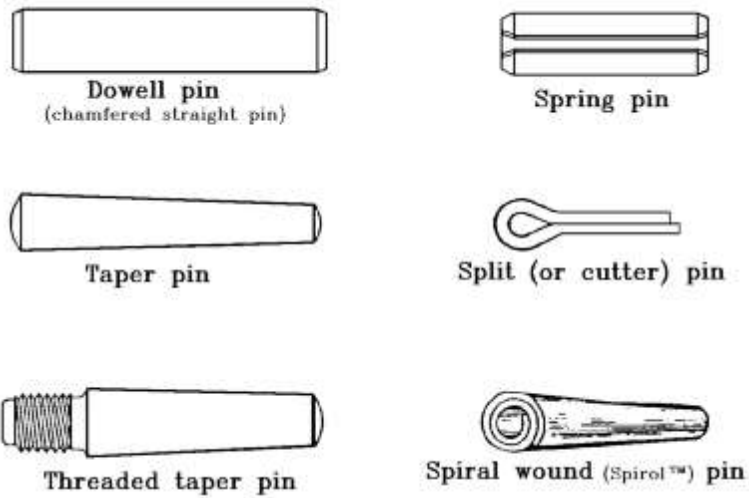

Figure 1-18
Removable pins for semi-permanent installation

Retaining rings (snap rings, circlips)

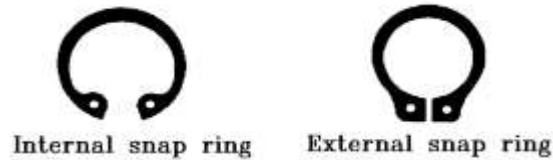

Figure 1-22
Basic types of retaining rings

Retaining rings are placed in a shallow groove on a shaft or in a housing bore on a machine. They are used to prevent or limit axial (longitudinal) movement of a shaft or a part. In addition, they provide shoulders for positioning machine components accurately on shafts and in housing bores and keeping them in place. The snap rings used in industry are usually made of spring steel which has good tensile strength and is resistant to shock.

Snap rings are divided into three sub-categories (see Figure 1-23):

- stamped metal flat rings;
- coiled wire rings (wire shaft rings);
- spiral rings.

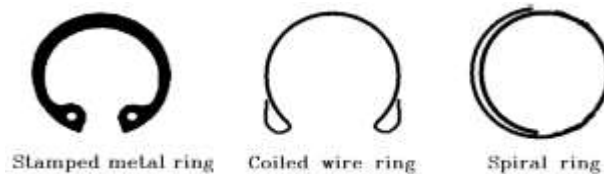

Figure 1-23

Springs

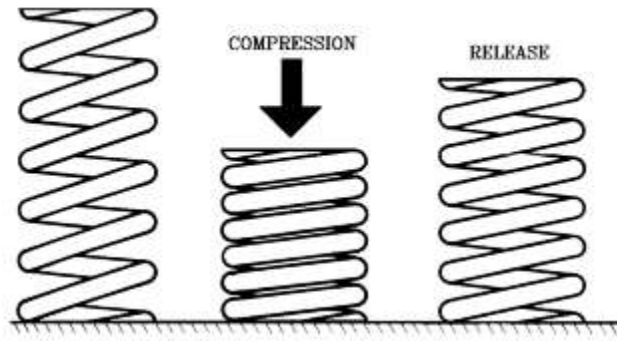

Figure 1-24
Spring

Springs are fasteners with elastic properties which are used to absorb shocks as well as for transmitting movement. Most are made of steel or bronze.

Washers



Figure 1-29
A typical metal washer

Washers are fastening accessories which are widely used in industry. Most are made of metal. Depending on their diameters and shapes, they can be used to increase the effective surface area of the part of the bolt head or the nut resting against the part, or to stop the bolt or nut from working loose. Non-metallic washers are used as insulators in certain kinds of electrical equipment and as thermal barriers between metallic parts. In other equipment, washers made of soft or elastic material are used to make joints watertight.

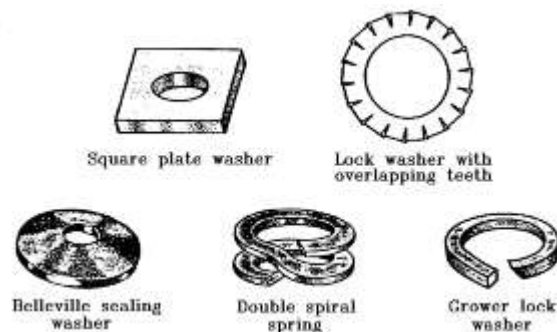

Figure 1-30
The principal types of washers

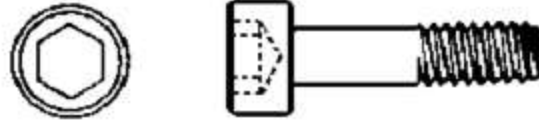

Figure 2-3
Hexagonal socket head cap screw

Allen keys (which come in a number of different sizes) are used to tighten and loosen bolts and screws with a hexagonal socket.

A torque wrench consists of an indicator handle and a set of sockets. It is used to tighten nuts, bolts and screws to either a rated torque or a specified torque, depending on the application. There are two types of indicator handles:

- those which give an audible click when the desired torque has been reached;
- those with pointers and dials which can be read directly.

NOTE: Torque is a system of two equal, parallel forces that are in the opposite direction.

Installing a bolt (or a metal screw)

Before a bolt is installed, it is important to know its rated tightening torque as well as its strength. The rated tightening torque is the maximum torque to which the bolt (or nut) can be tightened without causing it to become permanently deformed. The rated tightening torques for certain grades of bolts are shown in the table in Figure 2-4. Note that the rated tightening torques for lubricated bolts are lower than those for dry (degreased) bolts. The uncontrolled use of lubricants on bolts and nuts or metal screws, coupled with failure to reduce the maximum tightening torque when installing them, can cause them to become overloaded, deteriorate and break when the assembled parts are subjected to stress.



Installing snap rings (retaining rings)



Figure 2-15
Typical snap ring

Snap rings (retaining rings) are installed and removed with special pliers whose jaws are shaped to fit the holes in the lugs at the ends of the ring. There are pliers for use with internal rings and pliers for use with external rings.

NOTE: Always check to make sure the points of the pliers are the right size for the holes in the ring lugs.



Figure 2-16
Pliers for use with internal snap rings



Installing bolts and metal screws

Bolts and metal screws must be installed methodically if problems are to be avoided.

Preparation

Before installing and tightening a bolt or a metal screw, it is important to check the condition of each bolt or screw and the conditions of the holes into which they will be placed. The aspects to check during the inspection are:

- Thread quality and condition (check for damage);
- If there are cracks in the bolt or screw, or in the bolt hole;
- The condition of the head of the bolt or screw.

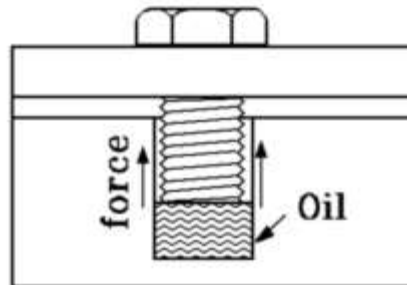

Hydraulic pressure in a tapped hole

The bolt holes are checked to determine the condition and quality of the thread and, if the hole is blind, to make sure it contains no oil or other liquid. If there is liquid in the hole, a hydraulic back-pressure can be produced as the bolt moves downward. This pressure can prevent proper seating of the bolt, so that, in effect, the bolt cannot be fully tightened.

Units of Torque

The symbol for torque is τ . The concept of torque, also called a moment of force or couple, originated with the work of Archimedes on levers. A force applied to a lever, multiplied by its distance from the lever's fulcrum, is the torque applied at that point.

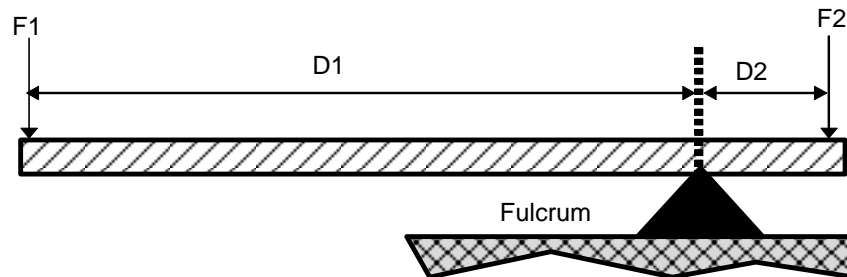

Torque is a force that tends to rotate or turn things around a pivot point. Basically, torque can be thought of as rotational force or a turning or twisting force. You generate a torque any time you apply a force using a wrench. Tightening the lug nuts on your wheels is a good example. When you use a wrench, you apply a force to the handle. This force creates a torque at the center of the lug nut, which tends to turn the lug nut.

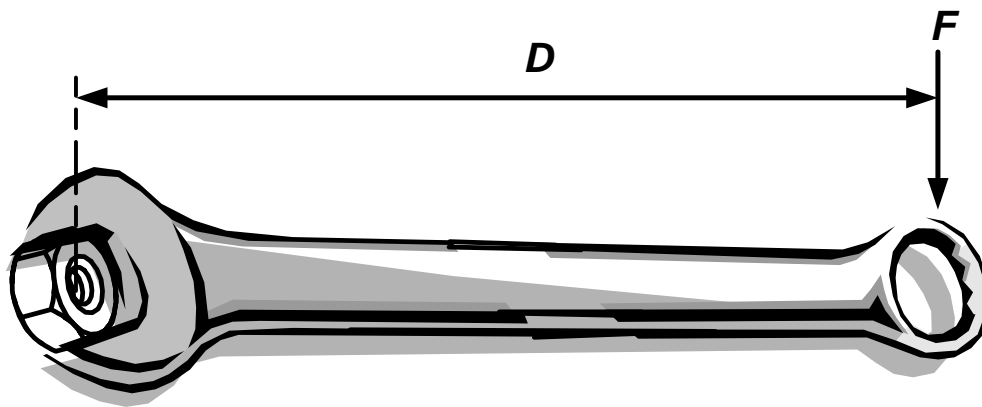

The force applied to a lever, multiplied by its distance from the lever's fulcrum, is torque. As a formula, you can define Torque as:

$$\text{Torque} = \text{Force} \times \text{Distance}$$

Torque Wrenches

A torque wrench consists of an indicator handle and a set of sockets. It is used to tighten nuts, bolts and screws to either a rated torque or a specified torque, depending on the application. There are two types of indicator handles:

- Those which give an audible click when the desired torque has been reached
- Those with pointers and dials which can be read directly



Beam or Pointer type



Click style

NOTE: Torque is a system of two equal, parallel forces that are in the opposite directions.

Installing a bolt (or a metal screw)

Before a bolt is installed, it is important to know its rated tightening torque as well as its strength. The rated tightening torque is the maximum



torque to which the bolt (or nut) can be tightened without causing it to become permanently deformed. The rated tightening torques for certain grades of American bolts are shown in the table on the following page.







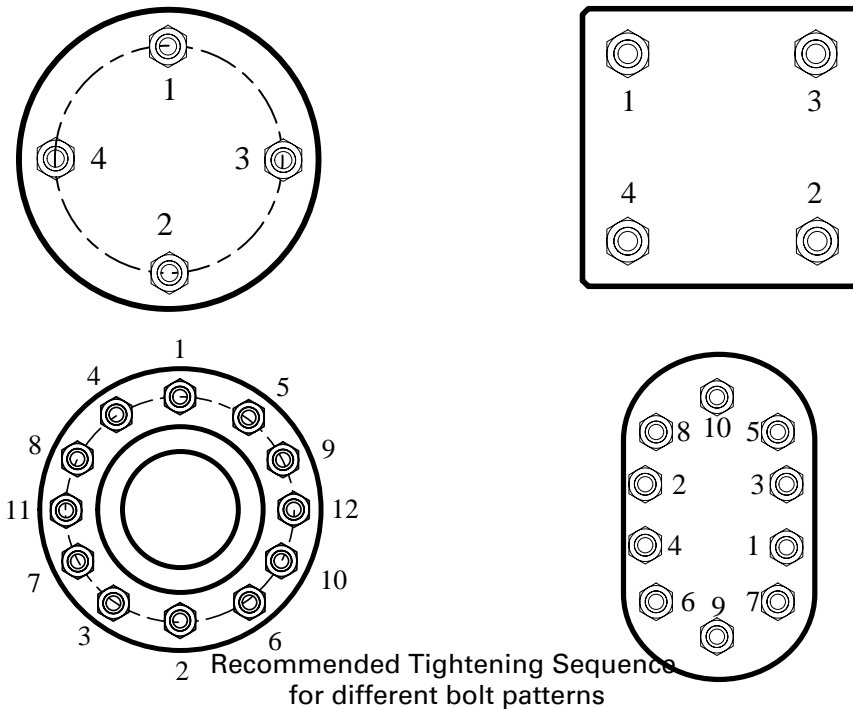



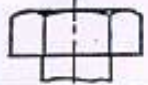
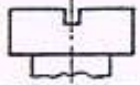

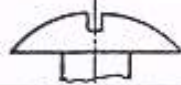
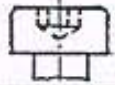
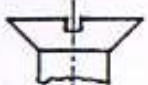





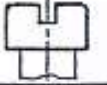





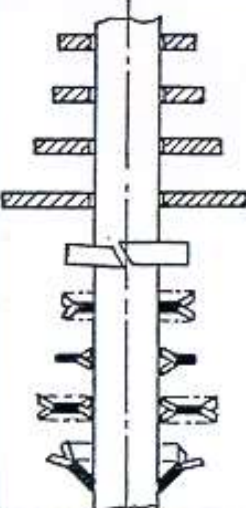

Note that the rated tightening torque for lubricated bolts are lower than those for dry (degreased) bolts.

The uncontrolled use of lubricants on bolts and nuts or metal screws, coupled with failure to reduce the maximum tightening torque when installing them, can cause them to become overloaded, deteriorate and break when the assembled parts are subjected to stress.

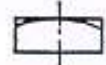
NOTE: The grade assigned to a bolt or screw reflects the properties of the metal or metal alloy it is made of, as well as its strength.

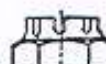

When an assembly requires several bolts, the tightening sequence shown above should be followed to make sure the parts will not warp or buckle.

| FASTENER SYMBOLS | | | | | |
|---|--|--|---|--|--|
| SCREW HEADS | | | | | |
| H  | C  | Q  | RL  | CHc  | |
| F/90  | FHc/90  | FB/90  | FB/90E  | CET  | |
| SET SCREW HEADS | | | | | |
| Hm  | Cm  | headless  | headlessHc  | QP  | Qm  |
| SET SCREW POINTS | | | | | |
| flat  | pointed  | cupped  | half dog  | full dog  | |
| WASHERS | | | NUTS | | |
|  <ul style="list-style-type: none"> Z · small M · medium L · large LL · extra large WZ · W · WL DE DI DD DF | | | H  | Q  | |
| | | | Hh  | HK  | |
| | | | Hm  | HK relieved  | |
| | | | C  | O  | |

DESIGNATIONS

I SCREWS vis

1. Type Fastener
2. Symbol of the head
3. Nominal diameter (ϕn)
Pitch if fine threads
L.H. if left hand threads
4. Length of screw (L)
5. Symbol type of finish (See Table A)
6. Class of Quality (See Table B)

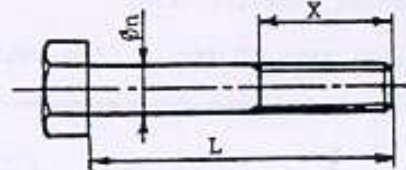

Example:
Screw H M6-45 T Class 5.6

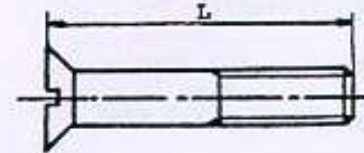







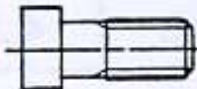

***NOTE**

- Thread Length X = $2\phi + 6$ for screws from 0 to 125 mm long
 = $2\phi + 12$ for screws from 125 - 200 mm long
 = $2\phi + 25$ for screws from 200 mm long and more

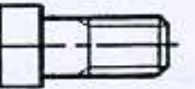
TABLE A

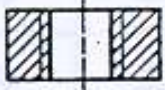
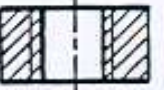
FINISH SYMBOLS

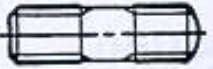
Heavy Lines Indicate Finished Surfaces

| Type of Finish | N - Rough | T - Semi Finished | | U - Precision |
|----------------------------|---|--|---|---|
| Manufacture | Forged | Forged | Machined | Machined |
| Vis Boulons Screw Bolts |  |  |  |  |
| Ecrous Nuts |  |  | |  |
| Goujons Studs |  | |  |  |



DRAWINGS and BLUEPRINTS



MECHANICAL DRAWINGS—INDUSTRIAL LIFE

Mechanical drawing is an intermediary between man and:

- the item to be made (to go from an idea to a real thing)
- his work (a means of achieving the work he does)
- those who participate in his work (a means of communicating between all the people on the work team).

For example, mechanical drawing:

- Defines the function, the overall dimensions, and the way to install a machine.
- Shows us the correct position of the different parts and how to place them.
- Gives precise information to the machinists in order for the parts to be made.
- Helps the designer to preview his design.

These are the reasons why you have to know how to read and interpret mechanical drawings, or blueprints, if you work in industry. The drawing office personnel (draftsmen, designers, etc.) must know even more technical information to prepare the documents.







DIFFERENT KINDS OF DRAWINGS

Because it is an intermediary between the persons who create a machine and the persons who make it, a drawing can take different forms according to its role and the people who will use it.

- Drawings for fabrication with standardized symbols--for mechanical, welding, buildings, electrical construction, etc.
- Sketches illustrating an idea, technical principle, description.
- Schematic explaining the operation of machines.
- Electrical, hydraulic, and pneumatic circuits.
- Curves, calculations of graphical statistics.
- Control instrument diagrams.
- Pictorial drawings for better visualization.

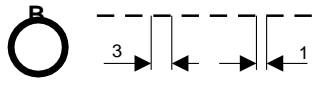
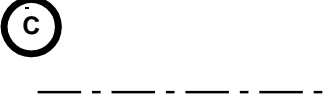

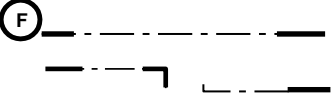
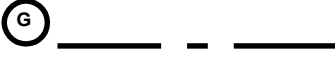
Draftsmen to indicate various drawing components use the following line types:

| TECHNOLOGY OF LINES | | | |
|---|----------------------------------|-------------|---|
| LINE | TYPE | WID | Function |
|  | CONTINUOUS THICK | 0.7 | – Visible Edges |
|  | BROKEN SHORT MEDIUM | 0.35 | – Hidden Edges |
|  | MIXED THIN | 0.18 | – Axis Of Symmetry – Hole Centers – Position – Pitch Circle Diameter |
|  | CONTINUOUS THIN | 0.18 | – Fictitious Edges – Dimension & Extension Lines – Leader Lines – Crosshatching – Revolved Sections |
|  | BROKEN THIN LONG | 0.18 | – Special Hatching – Architecture – Demolition |
|  | MIXED THIN, HEAVY ENDS & CORNERS | 0.18 0.7 | – Cutting Planes |
|  | MIXED HEAVY | 0.7 | – Special Surface Treatment |
|  | CONTINUOUS IRREGULAR THIN | 0.18 | – Partial Section – Broken Parts |



LINE SAMPLES:

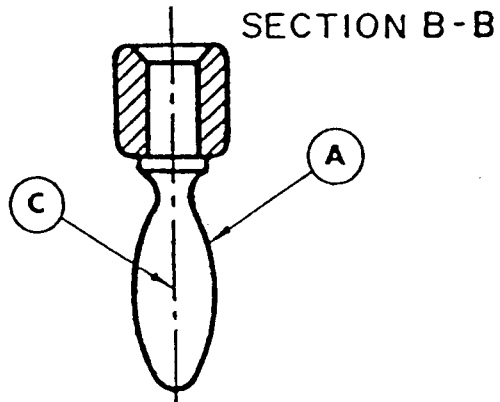
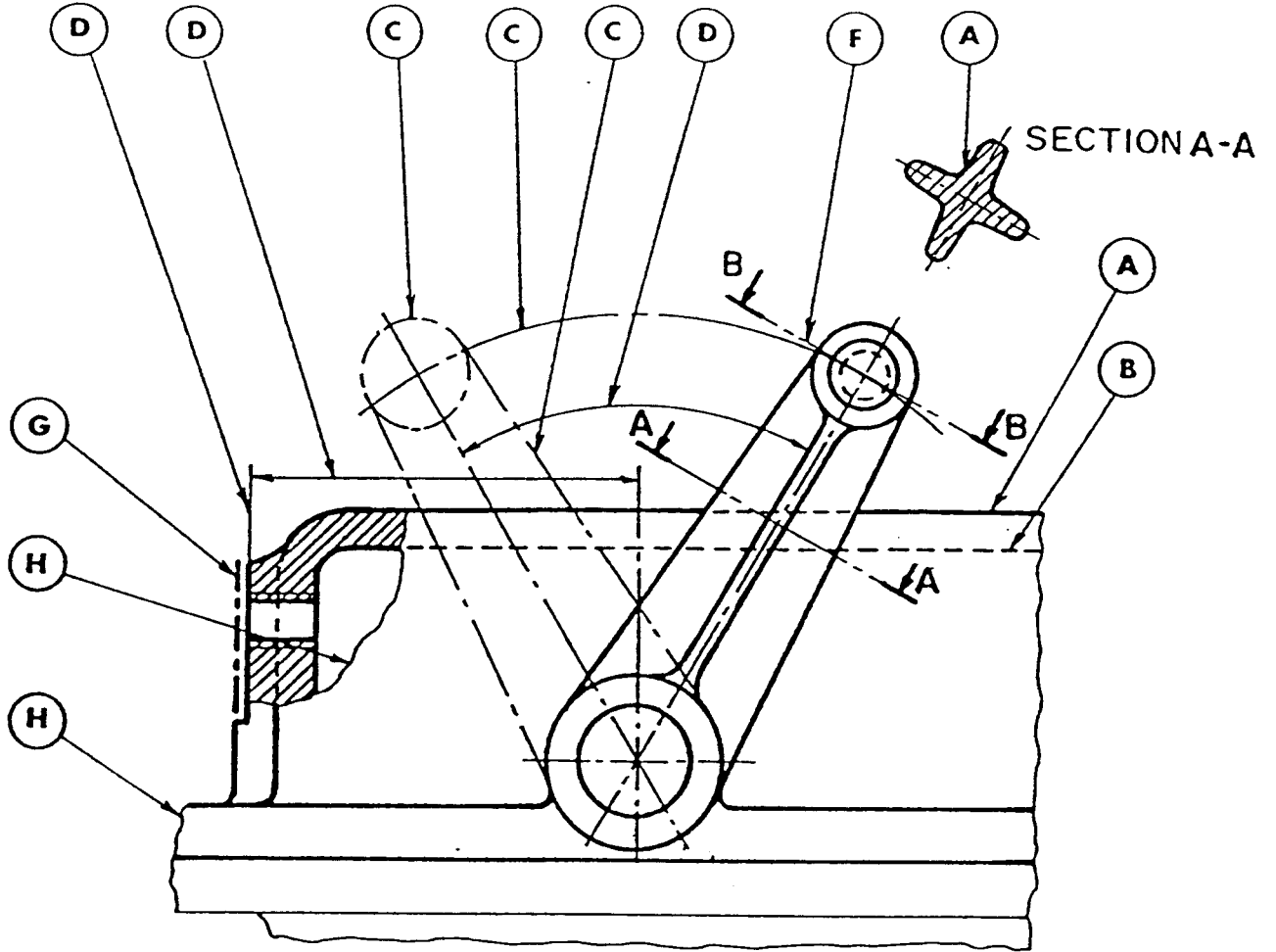



ORTHOAGONAL VIEWING

In our everyday experience or of, looking at objects, we rarely see their true shape.

A rectangular table appears as a parallelogram when we stand at one of its corners to look at it. Circular holes often appear to be oval. The reason for this is that unless we look directly at right angles to a surface, some of the lengths become foreshortened. In the case of the table, one of the diagonals appears to be shorter, and with the circles, one of the diameters.

If we are to produce a drawing in its true shape, we must view an object perpendicularly to its surfaces. This is the principle of orthogonal viewing. The word orthogonal means right angled.

Let us consider the orthogonal views of the item shown below.

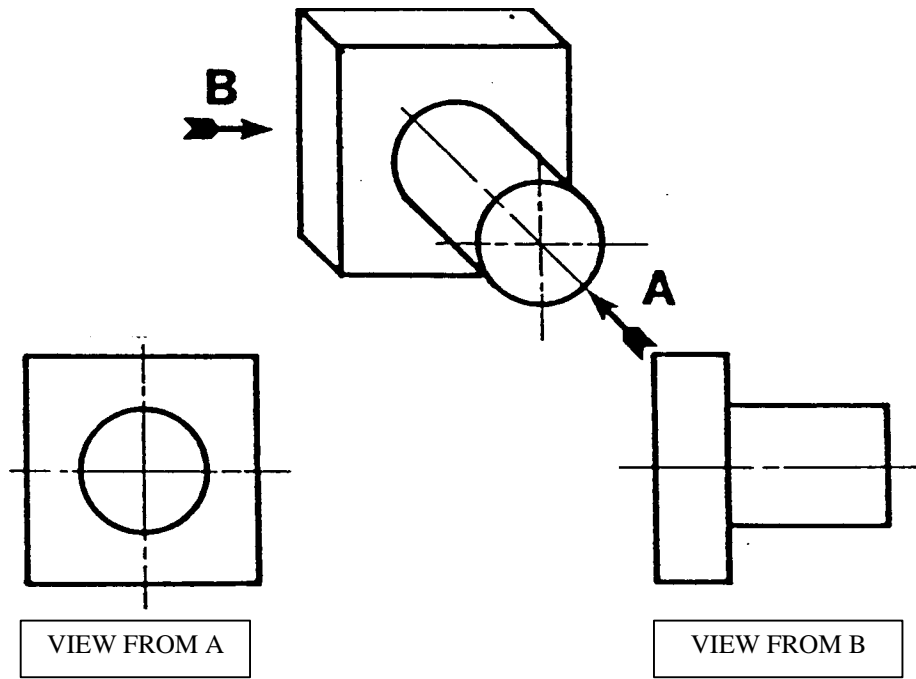



The oblique view shows a cylinder mounted on a square base. First, looking in direction A, we see a circle for the end of the cylinder. We cannot see any of the curved surface because this is in a line with our sight and is therefore "lost". Next, we see a square of the base, but again the thickness has disappeared.

Looking in direction B, we can see a rectangle for the side of the cylinder. No curvature is seen because all distances from the eye are lost and the ends become straight lines equal in length to the diameter, thus only a rectangle is seen. It is this type of viewing which we use in making mechanical drawings.



ARRANGEMENT OF THE VIEWS AND THEIR DESIGNATION

The name given to each view depends upon:

- The position of the front view - chosen as the most explanatory or descriptive view.
- Then giving names to each position according to where the observer must be to look at the corresponding view

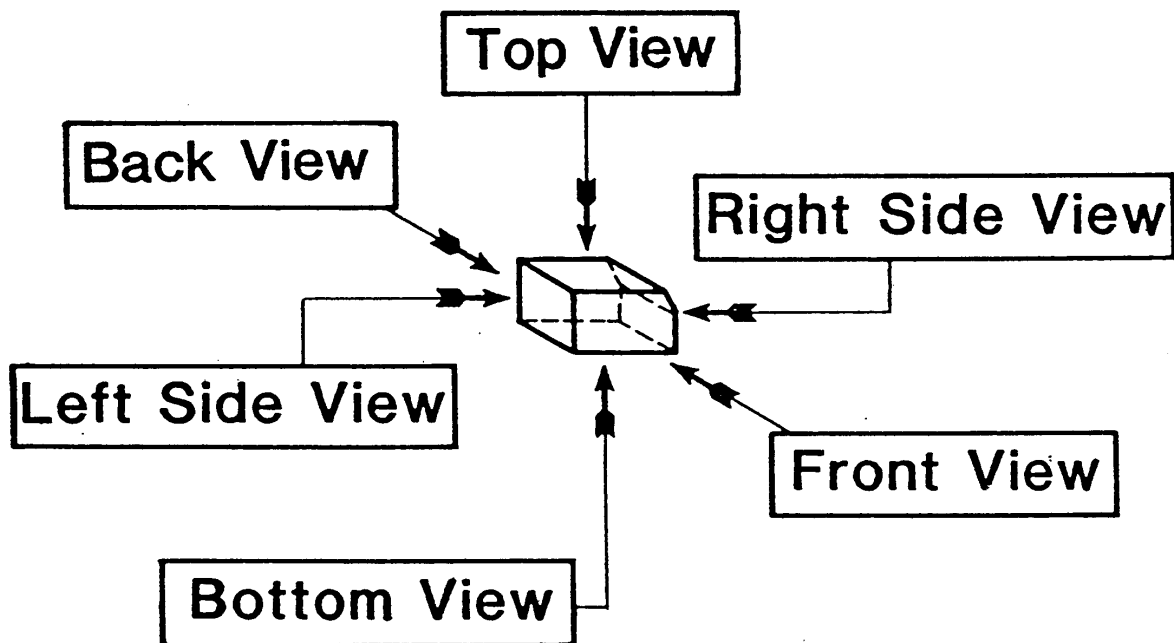

The arrangement of these views can fall into one of either two major categories:

- FIRST ANGLE PROJECTION (OR EUROPEAN PROJECTION)
- THIRD ANGLE PROJECTION (OR AMERICAN-US PROJECTION)

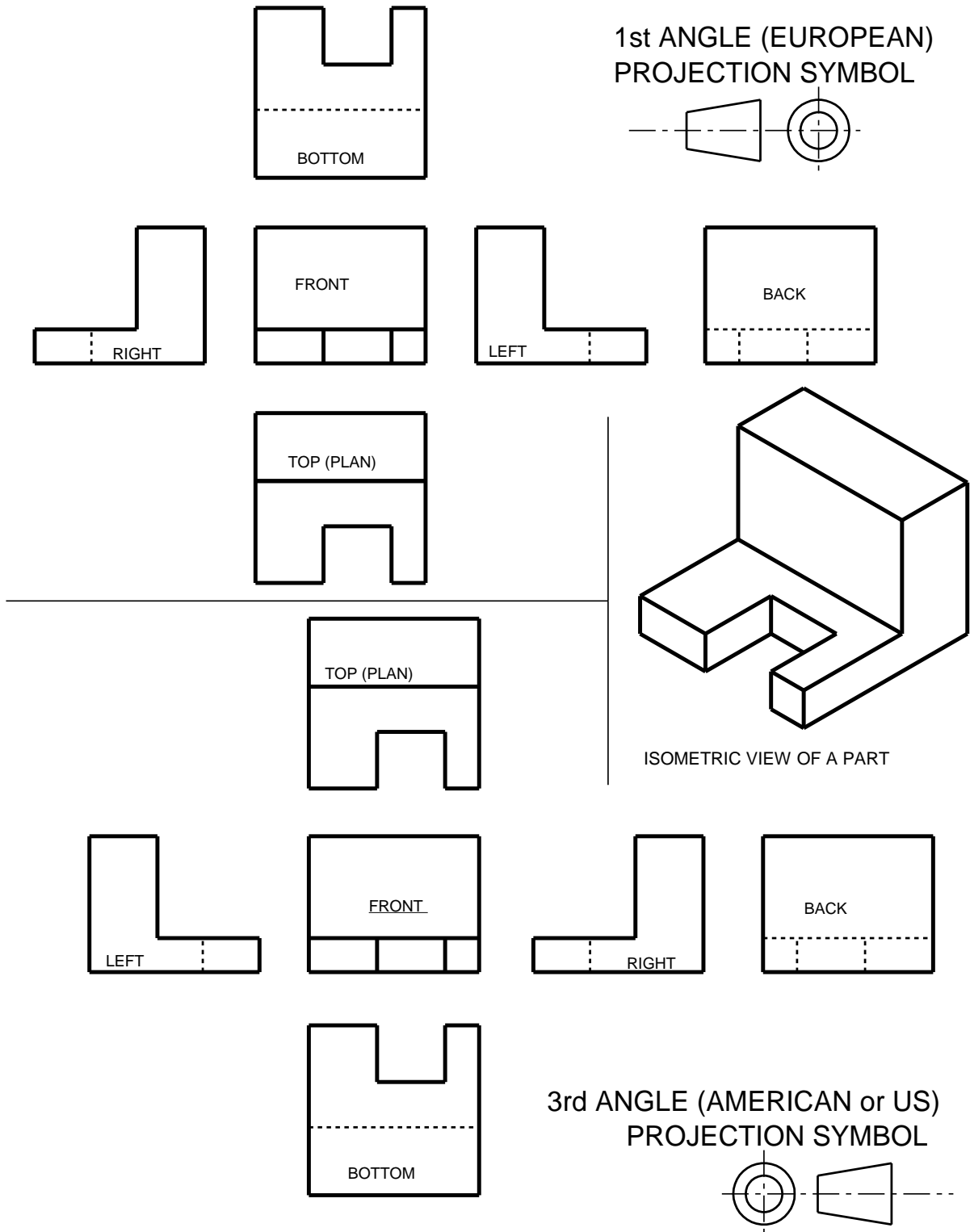



MITER LINE VIEW PROJECTION
3rd ANGLE (AMERICAN) PROJECTION

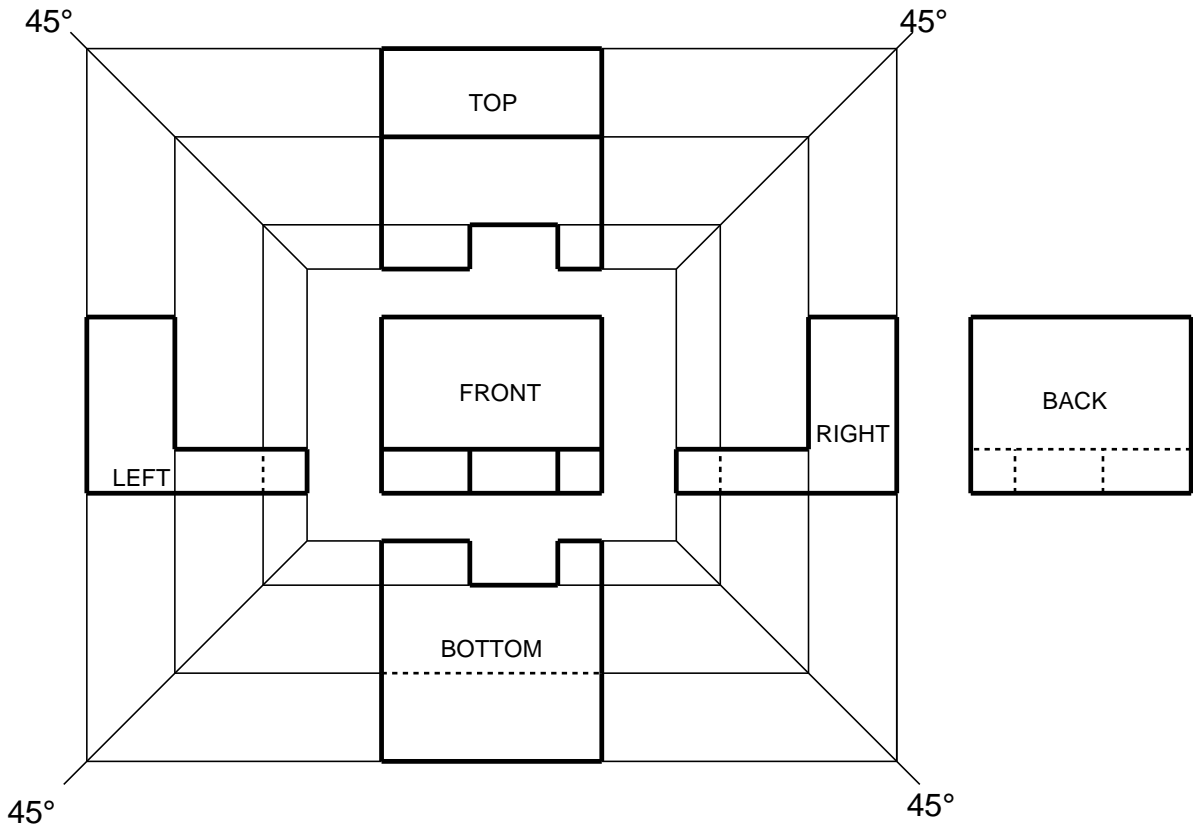



MITER LINE VIEW PROJECTION

1st ANGLE (EUROPEAN) PROJECTION

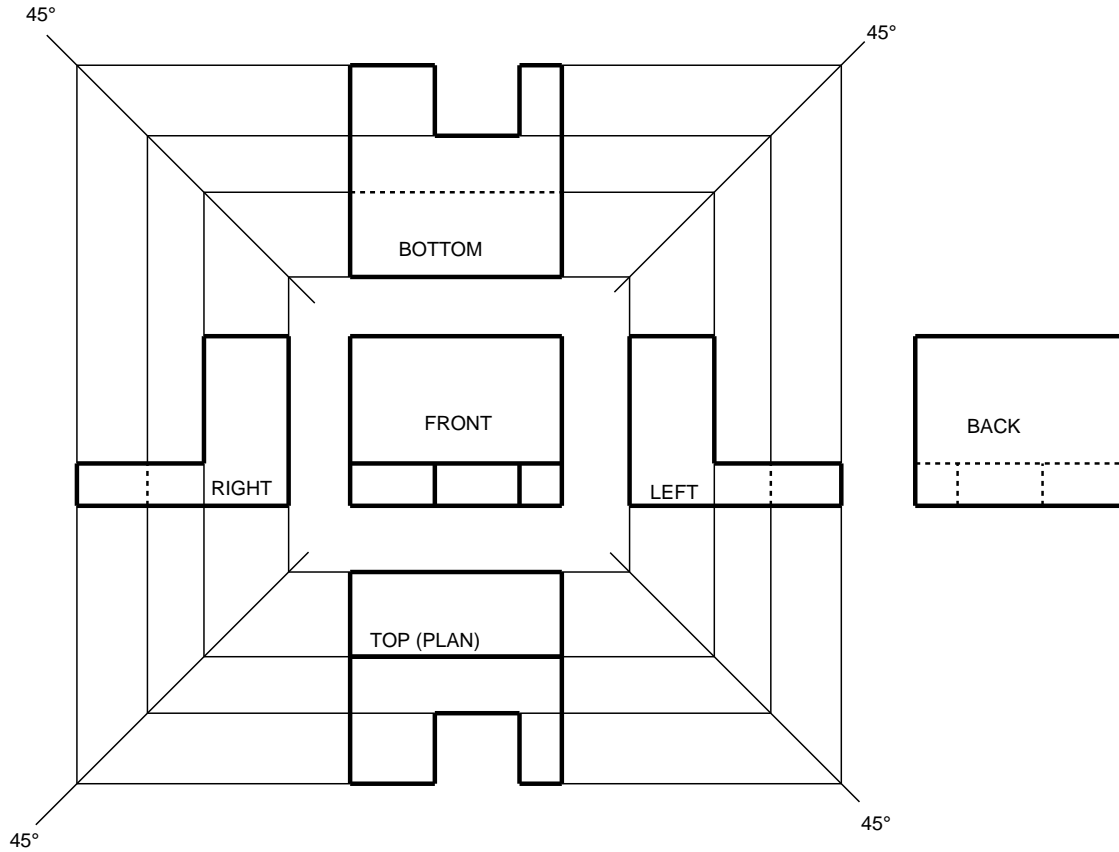



SPATIAL VIEWING EXERCISES

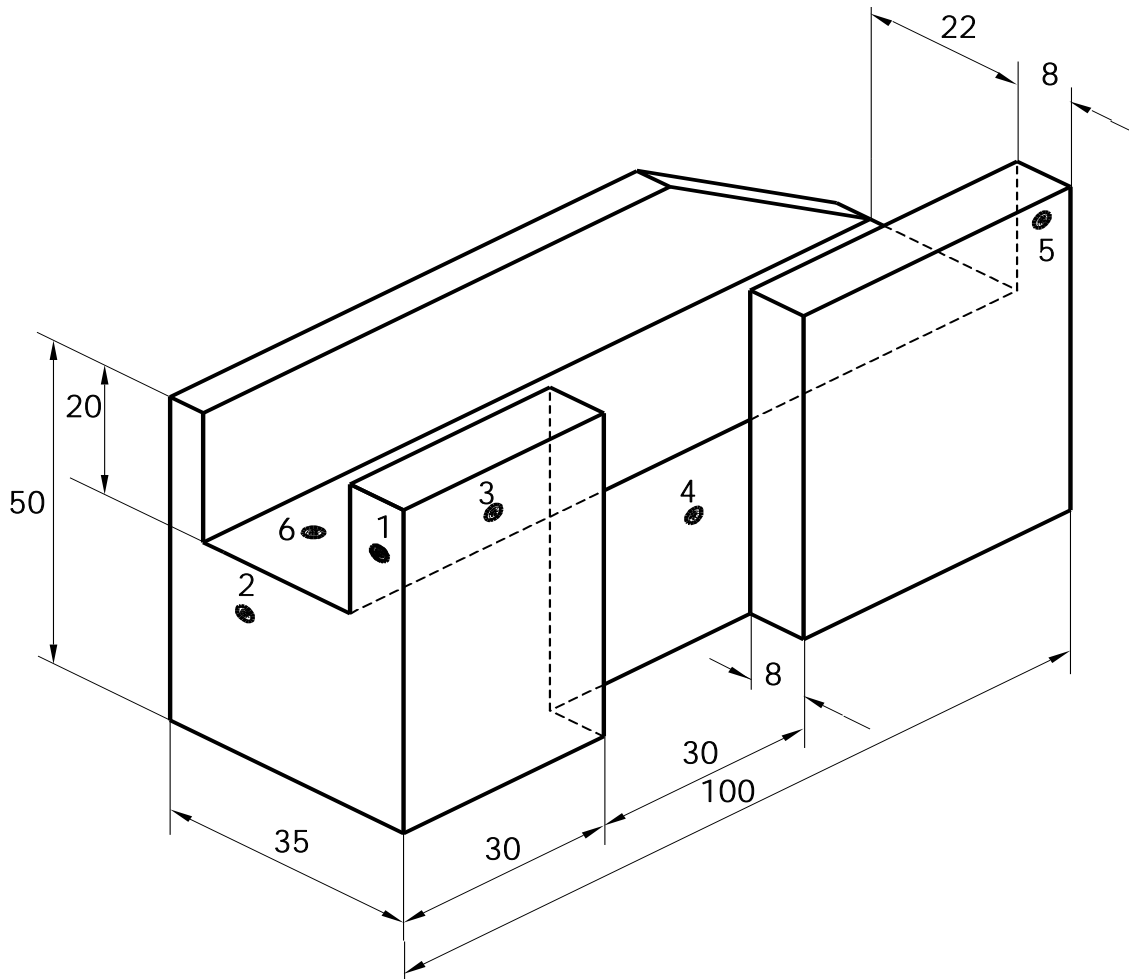

- 1) 70 (100-30)
- 2) 100
- 3) 13 (35-22)
- 4) 27 (35-8)
- 5) 8
- 6) 30 (50-20)

INSTRUCTIONS:

Above is an isometric view a machined part with 6 dots placed at various locations.

The goal is to determine the linear measurement of the thickness of the material behind each dot. In the event a slot or other air space is directly behind the dot, simply deduct the amount of air space as was done on point 3 of the example.

Drawing #1

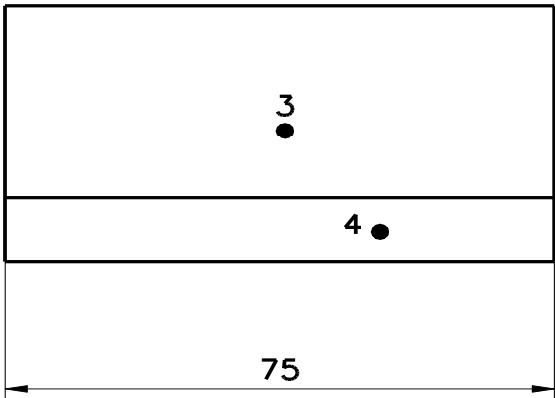

- 1) _____
- 2) _____
- 3) _____
- 4) _____
- 5) _____
- 6) _____

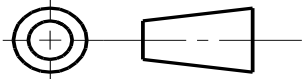
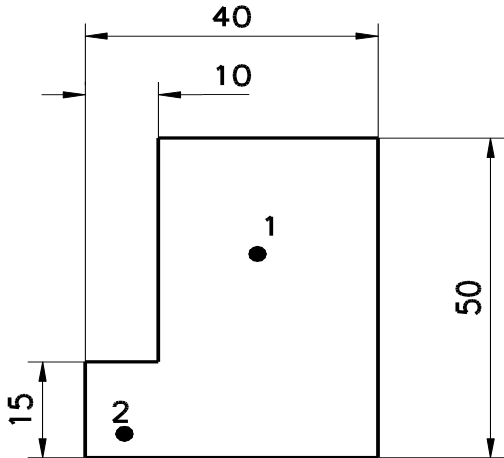
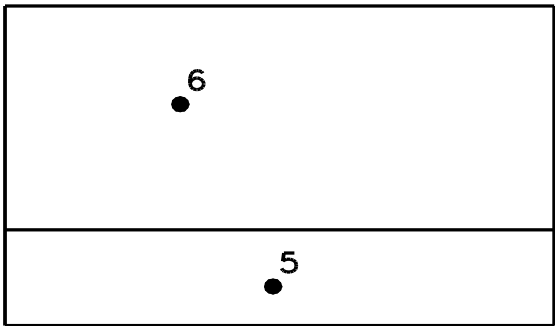

3rd angle projection



Drawing #2

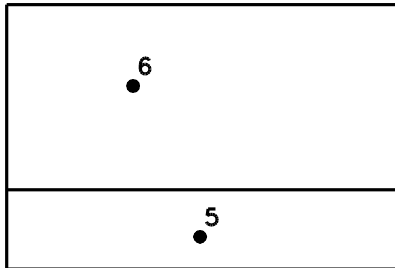
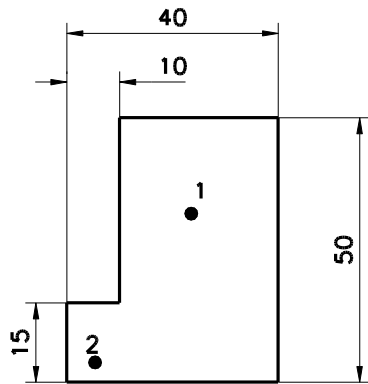

- 1) _____
- 2) _____
- 3) _____
- 4) _____
- 5) _____
- 6) _____

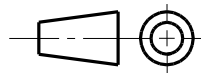
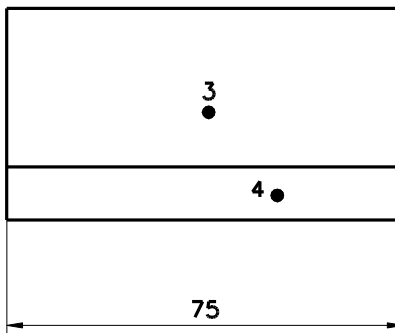

1st angle projection

Drawing #3

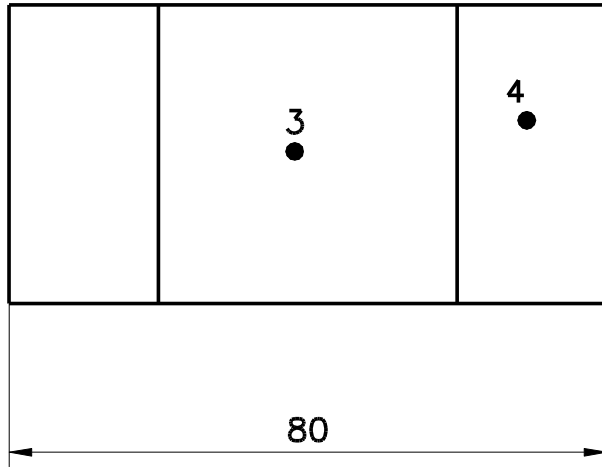

- 1) _____
- 2) _____
- 3) _____
- 4) _____
- 5) _____

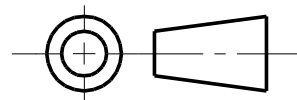
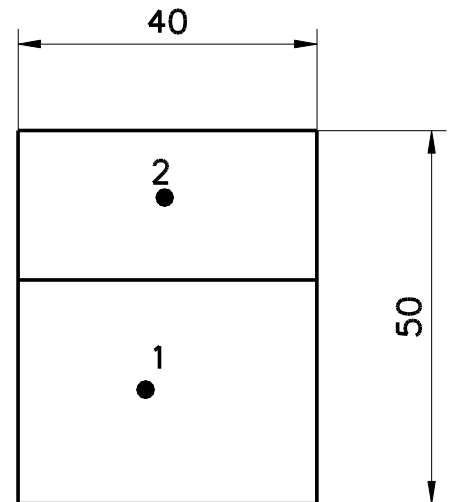
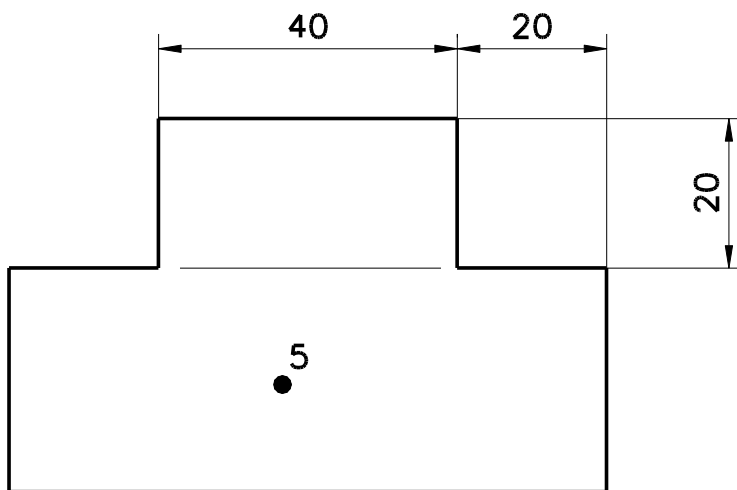

3rd angle projection



Answer for Spatial Vision Exercises

Drawing#1

Drawing#2

Drawing#3

1. 75

1. 75

1. 80

2. 75

2. 75

2. 40

3. 50

3. 50

3. 50

4. 15

4. 15

4. 30

5. 40

5. 40

5. 40

6. 30

6. 30

Sectional views

Let us imagine that the component shown on the previous page is to be manufactured. To do this, we need to know what it looks like inside.

If we take a vertical cut along the cutting plane line A-A (Fig. 1) and remove part of the component then what would be left would be that shown in Fig. 2.

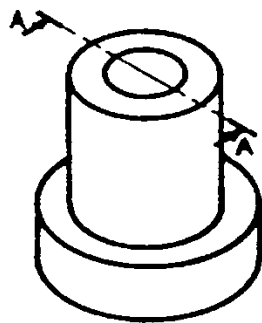

Fig. 1

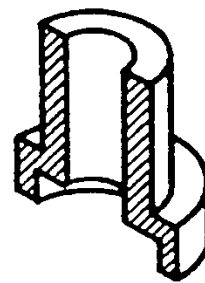

Fig. 2

A sectional view represents that part of an object which remains after a portion is assumed to have been cut or broken away and removed. Fig. 3 below shows how this part would appear on a detail drawing.

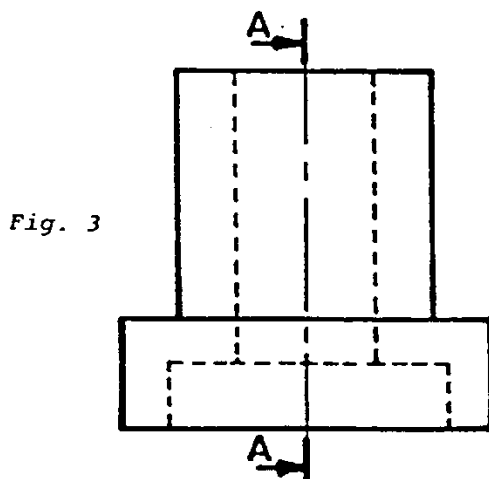
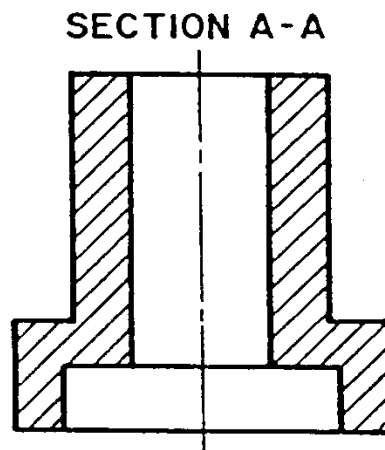
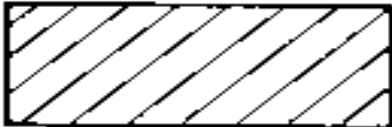
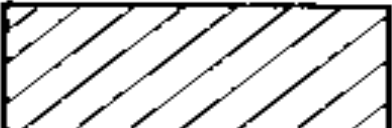
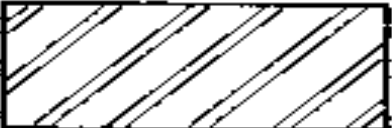



Fig. 3



1st angle (European) projection

| | |
|---|---|
| <p><i>Cross Hatch Patterns</i></p> <p><i>Detail Drawings</i></p> <p>RECOMMENDED FOR ALL DETAIL DRAWINGS</p> |  |
| <p><i>ASSEMBLY DRAWINGS</i></p> <p>STEEL AND CAST IRON (CAST IRON ONLY IN U.S.)</p> <p>ALUMINUM AND ALUMINUM ALLOYS (STEEL IN THE U.S.)</p> <p>COPPER AND COPPER ALLOYS (BRASS AND BRONZE)</p> <p>FRICITION MATERIAL</p> |     |



Assembly Drawings

Assembly drawings provided a pictorial view on how an assembly should be assembled. They should show enough detail and information that a maintenance technician can successfully complete the assemble of the component or machine. These drawings may also include specific information on location of certain parts of the assembly that require precision adjustment of their location or alignment to other components of the assembly.

On the following pages you will see assembly drawing 1-1048 along with practice exercises. **An answer key can be found at the end of this package.**

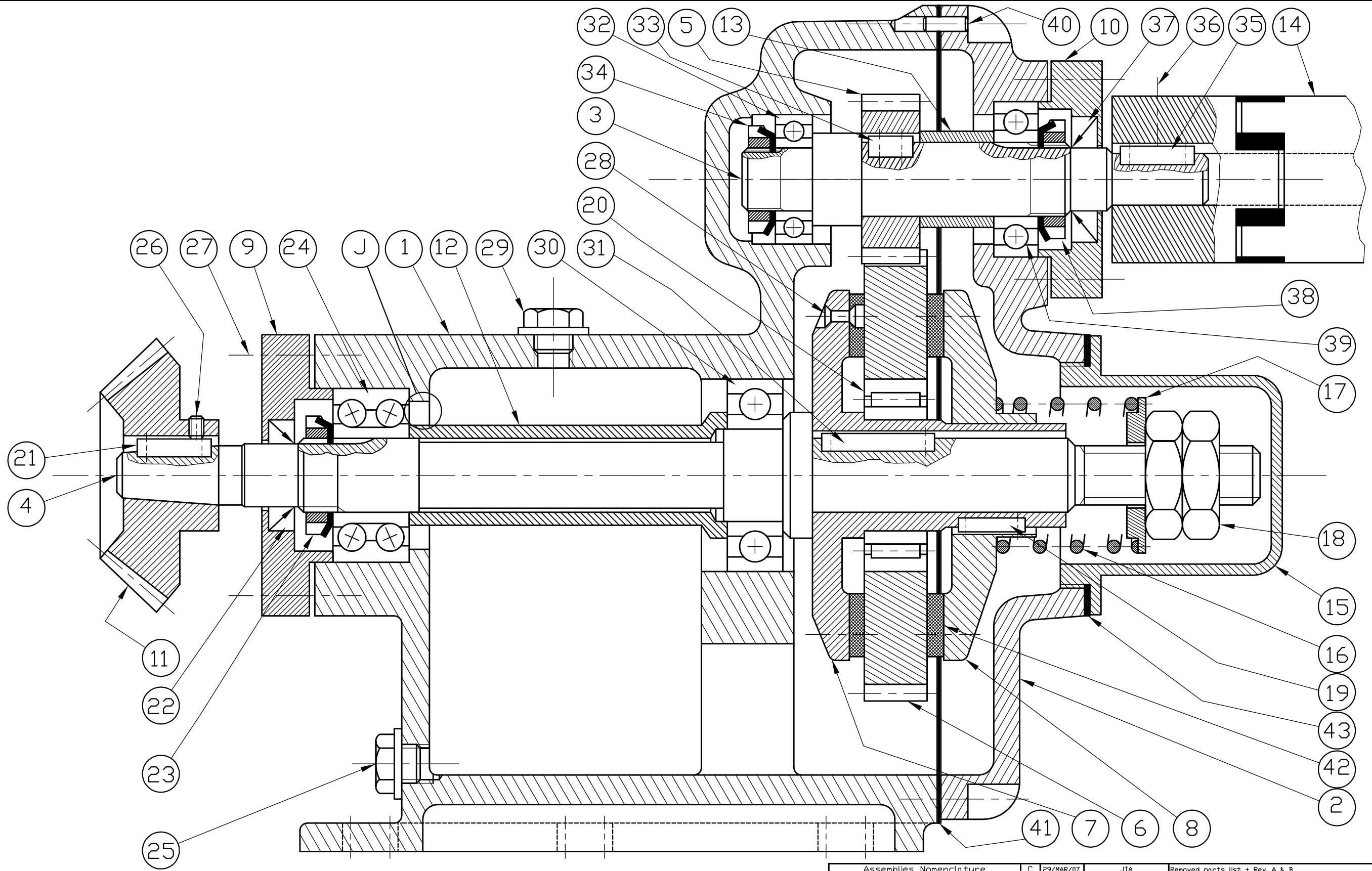

| | | | | | | | |
|---|-------------|--------|-----------|------------------|---------------------------------|-----------|--------|
| Assemblies Nomenclature | | C | 29/MAR/07 | JTA | Removed parts list + Rev. A & B | | |
| EXCEPT OTHER INDICATION | | - | 01/MAR/06 | J. T. Allen | Create document | | |
| General tolerances to be respected | WA + 10 | Mod | Date | By | Modification | | Weight |
| ISO 2768 | | | | | | | |
| Welding | | | | | | | |
| Sheet metal | | | | | | | |
| Mould | ISO8062 | | | | | | |
| Surface texture | ISO1302 | | | | | | |
| Welding symbol | ISO2553 | | | | | | |
| WARNING: All dimensions are in mm and projected view in ISD std. | | | | Reference Number | | | |
| | | | | ASSEMBLY | | | |
| MICHELIN | | | | 1-1048 | | Mod. C | |
| Toute copie imprimée de ce document n'est pas gérée. Propriété exclusive de notre société. Reproduction ou utilisation interdite sans notre accord écrit. Any printed copy of this document is not managed. Exclusive property of our company. Reproduction or prohibited use without our agreement. | | | | Drawing Number | | PUMA 2008 | |
| Units: | Sheet size: | Scale: | NTS | AutoCAD: | M 2008 | | |



1. Identify the following components of assembly 1-1048. Choose from answers from the list provided.

- | | |
|------------|---------------------------------------|
| #16. _____ | A. M8 screw |
| | B. Bevel gear |
| #19. _____ | C. Jam nut |
| | D. Spring retainer |
| #11. _____ | E. Spur gear |
| | F. Double row angular contact bearing |
| #24. _____ | G. Spring |
| | H. Set screw |
| #6. _____ | I. Single row ball bearing |
| | J. Lip Seal |
| #14. _____ | K. Shaft |
| | L. Coupling |
| #22. _____ | M. Key |
| | N. Gasket |
| #39. _____ | O. Cylindrical roller bearing |
| | P. Needle bearing |
| #23. _____ | Q. KM nut and MB washer |
| #4. _____ | |
| #26. _____ | |
| #41. _____ | |
| #20. _____ | |



1. What is the purpose of #29 and #25?
2. What is the purpose of #40?
3. Why is #24 used?
4. If #14 is providing an input of 500 RPMs, is the output RPM slower or faster?
5. Using information from question 4 and given that #5 has 32 teeth, #6 has 106 teeth and #11 has 26 teeth what is the output RPM?



PRECISION MEASUREMENT

Vernier calipers

The Vernier caliper can make both inside and outside measurements for a wide range of sizes. The most common size Vernier calipers are 6-inch, 12-inch. The Vernier caliper can make accurate measurements to 1/1000 (0.001) inch.

A Vernier caliper is shown in the figure below..

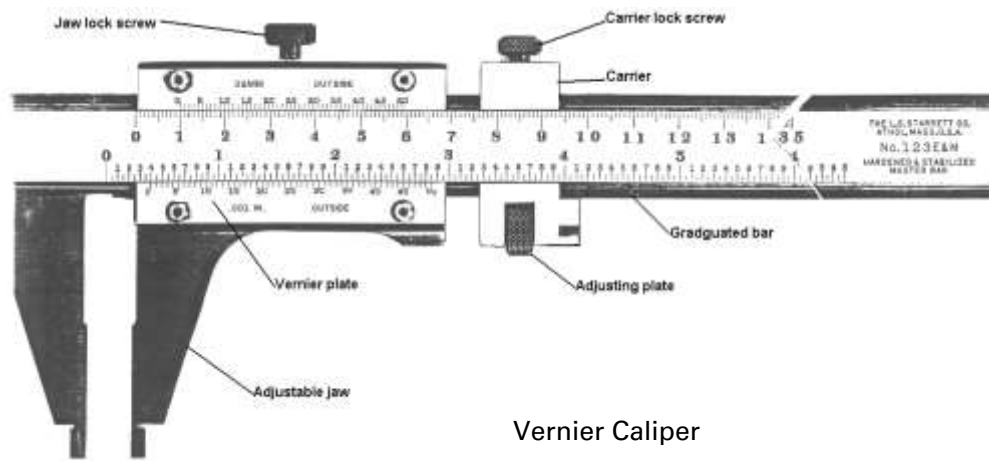

The basic parts of a Vernier caliper are main scale (similar to a steel rule) with a fixed jaw, and a sliding jaw with a Vernier scale which slides parallel to the main scale and is accurate to 0.001 inches.

The main scale is divided into inches and the inches are divided into 10 parts, each equal to 0.1 inch. The 0.1 inch divisions are divided into four parts equal to 0.025" each. The Vernier scale consists of 25 divisions.

The Vernier scale has 25 divisions in length equal to a length on the main scale that has 24 divisions. The difference between a main scale division and a Vernier division is 1/25 of 0.025" or 0.001".

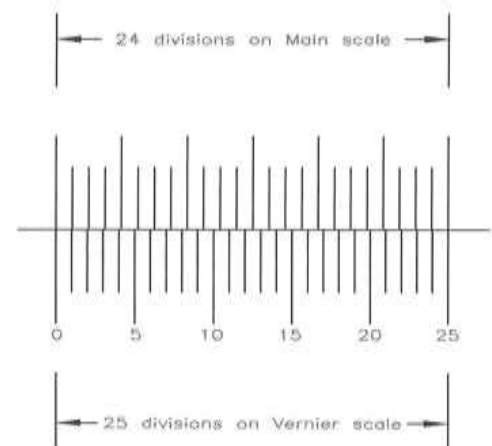

Vernier Scale



Another type of Vernier caliper is shown in figure below. This type uses separate jaws for inside and outside measurements. However, this caliper is read the same way.

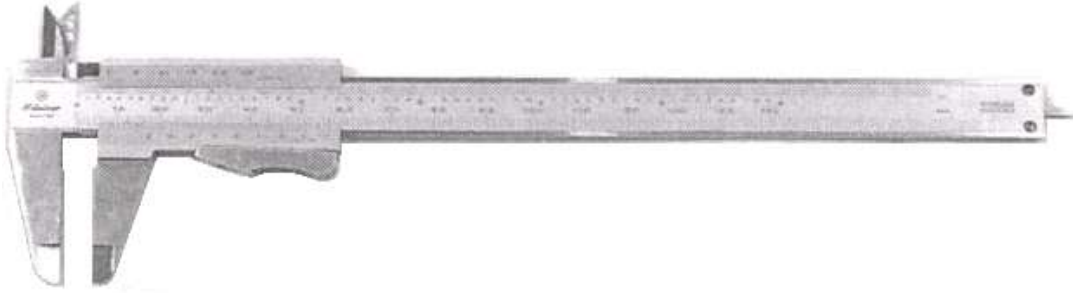

Figure below shows how the Vernier caliper is used to measure two kinds of diameters.



Reading a Vernier caliper

Follow these steps to read a Vernier caliper:

1. On the main scale, count the number of inch divisions, 0.1" divisions, and 0.025" divisions that are to the left of the zero (0) mark on the Vernier scale.
2. On the Vernier scale, find the mark that most closely aligns with a mark on the main scale. This mark gives the number of thousandths that are added to the main scale reading.



For example, the measurement set on the Vernier caliper in figure below would be read as follows:

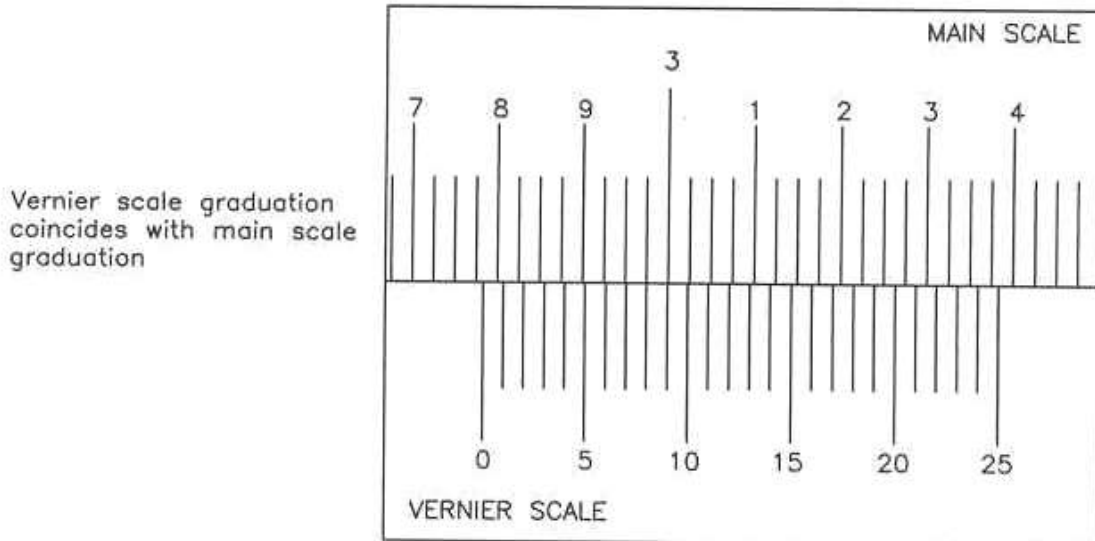

1. In reference to the zero (0) division on the Vernier scale:
 - a. Read two 1-inch divisions = 2.000"
 - b. Read seven .1-inch divisions = 0.700
 - c. Read three .025-inch divisions = 0.075
$$\underline{2.775}$$
2. On the Vernier scale: Determine which Vernier mark most closely aligns with a main scale Mark. In figure above, the eighth (8th) Vernier scale mark lines up with a main scale mark. Therefore, 0.008" is added to 2.775". The overall measurement is 2.775" + 0.008" = 2.783"

Micrometers

A micrometer is a widely used device for precisely measuring thickness, outer and inner diameters, and depths. The advantages of this instrument over others like Vernier Calipers, is that they are easy to use, and their readouts are more precise and consistent.

Micrometers have a lot of pieces involved in them. The major ones are shown in figures below. The operational principle involved is the “Nut and Screw”. Micrometers have a fixed fine pitch nut inside. The screw will move forward by a distance equal to its pitch. Using graduated divisions, micrometers indicate the movement, of the end of the screw in relation to fixed contact (Anvil).

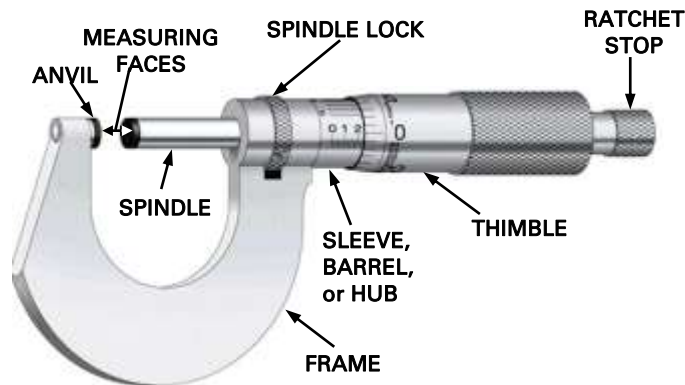

Other interesting features of micrometers are the incorporation of spring-loaded twisting handle that will ratchet at a certain torque. Normally you do the rough movements using the thimble, but not the final approximation. This is because one could use the mechanical advantage of the screw to force the micrometer to squeeze the material; using the Ratchet the micrometer will not continue to advance once sufficient resistance is encountered. Because of that the measurements are more coherent and repeatable.



Holding a Micrometer

Types of micrometers

The figure to the right is showing different types of micrometers. You must select one which adjusts to the measurement that you want to take. Micrometers come in different measurement ranges, which can vary depending on the model (i.e. 0-25mm, 25-50mm, 0-1 inch, 2-3 inches, etc.)

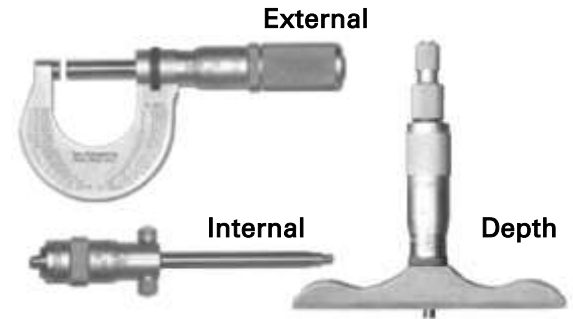

Types of Micrometers

An external micrometer is typically used to measure wires, spheres, shafts and blocks. Internal micrometers are used to measure the opening of holes, and a depth micrometer typically measure depths of slots and steps.

Reading an inch-system micrometer

The spindle of this micrometer has 40 threads per inch, so the pitch is 0.025 inch ($1/40 = 0.025''$). This is the distance between two graduations of the barrel. The 25 graduations on the thimble allow the 0.025 inch to be further divided, so that turning the thimble through one division moves the spindle axially 0.001 inch.

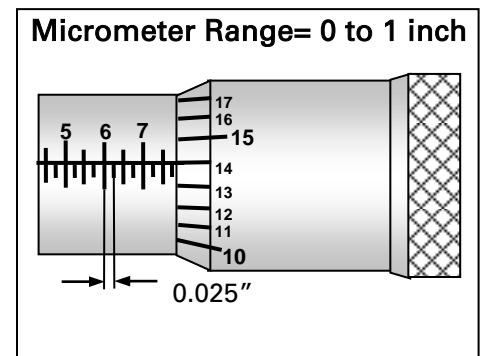

To read an inch-system micrometer:

Micrometer Reading (inches)

1. Count the number of whole divisions that are visible on the barrel scale and multiply by 25. The numbers 1, 2, 3, etc. appear every fourth sub-division on the barrel. Each number represents one hundred thousandths. This makes it easier to take readings mentally (i.e. Figure above is showing $0.700'' + 3 \times 0.025'' = 0.775''$).
2. Find the division on the thimble which coincide with the axial zero line on the barrel (i.e. Figure above is shown 14 = $0.014''$). This is the number of thousandths that you have to add to the previous reading in step 1
3. Add both step 1 and step 2 readings (i.e. $0.775'' + 0.014'' = 0.789''$). This is the final reading in thousandths of an inch.



To read a metric micrometer:

1. Count the number of millimeters and add any half divisions that are visible on the scale on barrel (i.e. figure to the right is showing 33 mm + 0.5 mm = 33.5 mm).
2. Find the division on the thimble which coincides with the axial zero line on the barrel (i.e. figure to the right shows 49 = 0.49 mm).
3. Add step 1 and step 2 readings (i.e. 33.5 mm + 0.49 mm = 33.99 mm). This is the final reading in hundredths of a millimeter.

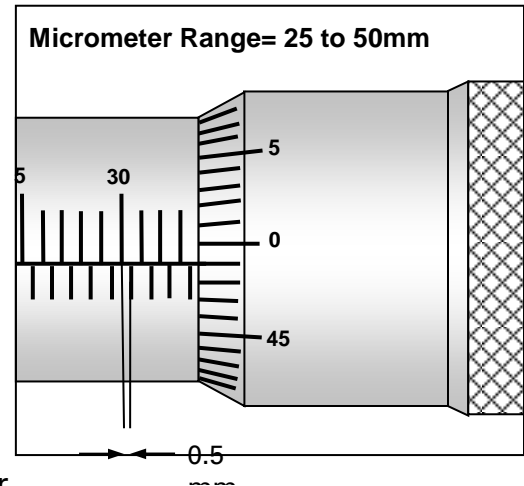

Micrometer Reading (mm)

Dial indicators

Dial indicators are instruments that accurately measure a small distance and are used to find the dimensional differences between different areas of a part or between the parts to be measured and a gauge block or other reference surface. They may also be known as a **Dial gauge**, or as a **Dial Test Indicator (DTI)**.

All these instruments are designed to amplify dimensional differences by mechanical, pneumatics, optical or electrical means. The mechanical ones use the operational principles of "Rack and Pinion, and Gears". Rack and pinion system is used to transform lineal motion in rotational motion; gears with different numbers of teeth are used to achieve good output amplification reading

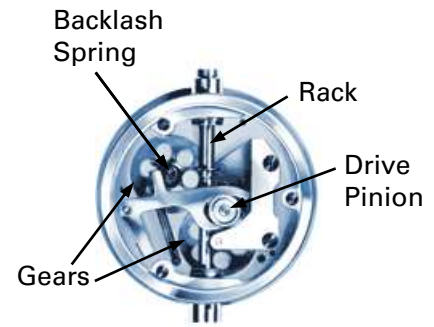

Mechanical Dial Indicator

Dial indicators may be used to check the variation in tolerance during the inspection process, to initially set up or calibrate a machine, shaft alignment, check for consistency and accuracy in the manufacturing process, check run out to centering lathe's work piece, measure the deflection of a beam or ring under laboratory conditions, as well as many other situations where a small measurement needs to be registered or indicated. The mounting of dial indicators can be made several different ways. The most commonly used method is using a magnetic base as shown in figure below.

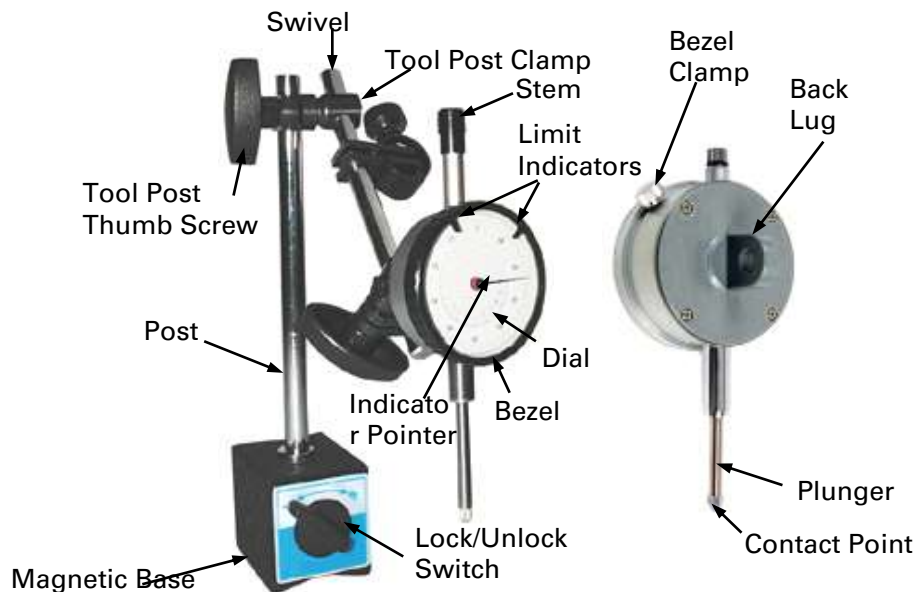

Dial Indicator with Magnetic Base



Dial Indicator Types

Reading a dial indicator

The dial indicator is used most often in conjunction with either a surface plate or an indicating jig or affixed directly to the machine member. To read a dial indicator:

1. Select a dial indicator suitable for the work you want to do. Keep in mind both range and precision.
2. Select the kind of holding device you need. The device employed to hold the dial indicator should be as compact and rigid as possible to minimize any error due to bending of support.
3. Select the reference surface, datum point, etc. The reference surface should be clean.
4. Touch the indicator plunger to the datum point and go down approximately one half of Full Indicator Movement. This insures that the plunger can travel in both directions. It is important to be able to read both positive and negative travel.
5. Rotate the dial in either direction to set the zero.
6. The measurement is read directly from the dial, taking into account if the reading is positive or negative. That depends on the direction of travel of the plunger. You also have to count how many whole turns the pointer traveled and add this amount to the reading.

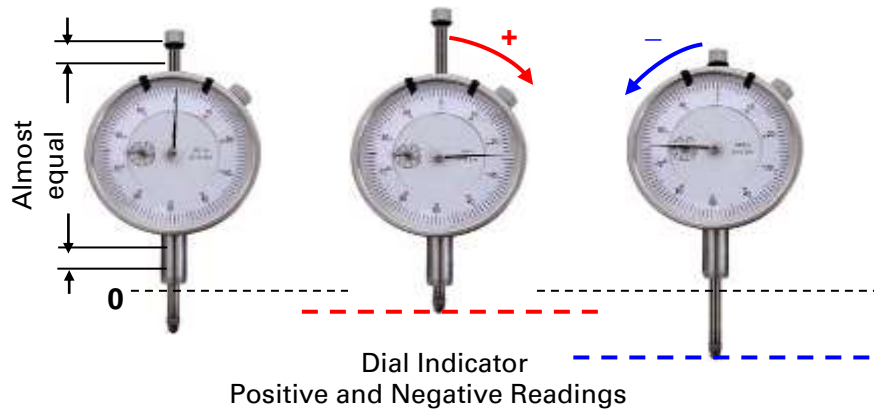

Height gauge

A height gauge is a tool which is normally used on a known flat surface such as granite surface plate. Some of them have a Vernier scale for more accurate readings. Standard height gauges are available up to 2150 mm or 85 inches and accuracy of 0.02 mm (0.001").

These measurement tools are used to measure vertical distances and for layout in metalworking or metrology. The figure to the right is showing the major parts of a Vernier height gauge.

In some Vernier height gauge models the main scale can be adjusted to zero by a fine feed screw or rack and pinion system at the top of the gauge, this adjustment allows different scribes or probes to be used, as well as adjusting for any error. The carrier slide is used for fine adjustments. The Vernier scale is read exactly the same as Vernier calipers.

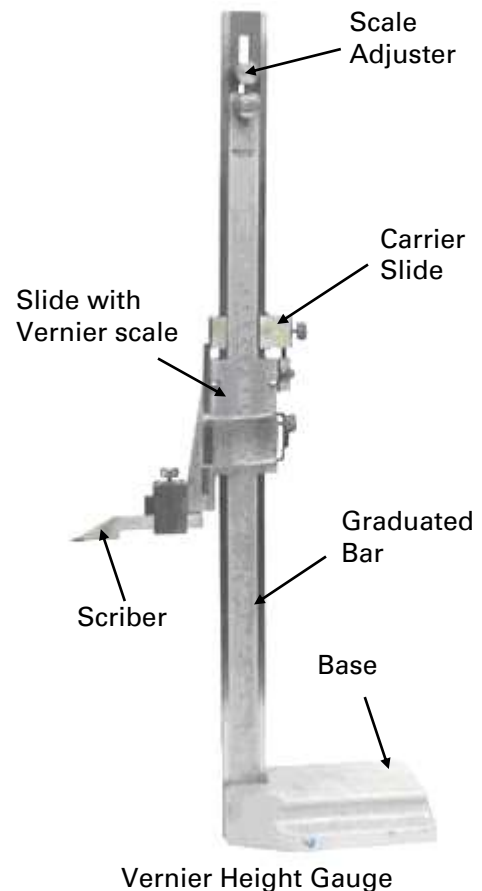



Answers for Assembly Drawing 1-1048

1. Identify the following components of assembly 1-1048.
Choose from answers from the list provided.

#16. G

#19. M

#11. B

#24. F

#6. E

#14. L

#22. J

#39. I

#23. Q

#4. K

#26. H

#41. N

#20. O



6. What is the purpose of #29 and #25?

29 is fill plug for oil, 25 is the drain plug for oil

7. What is the purpose of #40?

Align pin for housing #2

8. Why is #24 used?

Because there are axial and radial loads due to the use of bevel gears

9. If #14 is providing an input of 500 RPMs, is the output RPM slower or faster?

Slower

10. Using information from question 4 and given that #5 has 32 teeth, #6 has 106 teeth and #11 has 26 teeth what is the output RPM?

$$\frac{rpm_2}{rpm_1} = \frac{\#teeth_1}{\#teeth_2} = \frac{x}{500} = \frac{32}{106} = 16000 = 106x = 151rpm$$