

MICHELIN TECHNICAL DATA

2025 MATERIAL HANDLING

*INDUSTRIAL PNEUMATIC TIRES
RADIAL TECHNOLOGY*



MICHELIN



MICHELIN TECHNICAL DATA

INDUSTRIAL PNEUMATIC TIRES
RADIAL TECHNOLOGY

TABLE OF CONTENTS

TIRE RANGE	PAGE 4
INTRODUCTION	PAGE 5
PRODUCT PRESENTATION AND CHARACTERISTICS	
MICHELIN XZR	PAGE 6
MICHELIN XZM	PAGE 10
MICHELIN XZM 2+	PAGE 26
MICHELIN X STACKER 2	PAGE 28
MICHELIN X STACKER 3 HD	PAGE 30
MICHELIN X STRADDLE 2	PAGE 32
MICHELIN X TERMINAL T	PAGE 36
MICHELIN X TERMINAL T HD	PAGE 38
MICHELIN X AGV ^{EV}	PAGE 40
INDUSTRIAL TIRES	PAGE 43
GENERAL INFORMATION	PAGE 44

TIRE RANGE



**MICHELIN
XZR**



**MICHELIN
XZM**



**MICHELIN
XZM 2+**



**MICHELIN
X STACKER 2**



**MICHELIN
X STACKER 3 HD**



**MICHELIN
X STRADDLE 2**



**MICHELIN
X TERMINAL T**



**MICHELIN
X TERMINAL T HD**



**MICHELIN
X AGV^{EV}**

INTRODUCTION

The content provided in this document is intended for informal purposes only. It may not be used or relied upon for legal or statutory actions.

For technical and safety reasons, a tire should never be used beyond the limits of the technical specifications for which it has been approved. All recommendations provided in this document should be followed. Michelin is not responsible for any usage, fitting, storage, maintenance or handling actions outside of the stated recommendations.

MICHELIN® tires are designed for a specific use as defined in this catalog. Any other usage constitutes an abnormal use. However, in some circumstances, Michelin may issue a waiver which will specify the conditions and the permitted operational limits for a specific application. If a tire is to be used differently than what it is designed for, please consult your nearest Michelin Representative for further guidance. Michelin expressly denies any responsibility for any abnormal use of its tires or any use different from the tire's intended design in the absence of express written permission (derogation) from an authorized Michelin Representative.

Further, correct usage and maintenance are necessary to achieve proper performance and to maximize life. Therefore, it is recommended that users adhere to all safety and usage recommendations. However, you must note that these recommendations may be subject to more restrictive local legal and/or regulatory requirements.

Specifically, tire load and pressure tables included in this book are classified according to the various applications of machines. In the load and pressure tables, the shaded boxes indicate the normalized values. These values reflect optimal use, the best balance of performances. Again, these values are given for informational purposes only and may not be used for legal or statutory actions.

Finally, unless otherwise specified, MICHELIN® off-the-road, industrial, and compact tires comply with internationally accepted standards that are established by TRA (Tire and Rim Association), ETRTO (European Tire and Rim Technical Organisation), JATMA (Japan Automobile Tire Manufacturers Association), and/or ISO (International Standards Organisation). Among other things, the standards encompass load capacity, inflation pressure, overall diameter, overall width, and related valves and rims. Some minor differences may exist between these standards.

Following publication, the information herein is subject to change in Michelin's sole discretion.



1 SPEED

Capable of reaching up to 50 km/h ⁽¹⁾

The radial technology, tread pattern and specific rubber compounds allows for higher speeds.

2 SAFETY

Exceptional grip for short distance braking

The radial structure and multi-block pattern provides maximal ground footprint.

3 ROBUSTNESS

Limit machine downtime

Radial tubeless construction to prevent punctures and damages.

TIRE CHARACTERISTICS

ADDITIONAL INFORMATION

VEHICLE EQUIPMENT



The XZR tire is the solution for baggage tractors, urban machines and other high intensity forklift applications. Customers can expect an exceptional total value of ownership.

- Michelin Industrial and Port Tires Product Manager

⁽¹⁾ Characteristic of the product measured with the TKPH indicator.

LEARN MORE

ON THE WEB
business.michelin.co.uk

TESTIMONIALS
youtube.com/michelinearthmover

TOOLS

BEYOND ROAD SELECTOR
beyond-road.selector.michelingroup.com/mh

CONTACT

Please contact your local sales representative for more information.

TECHNICAL CHARACTERISTICS



DESCRIPTION	CAI [MSPN]	Max.dist./ hour km [mile]	Section width mm [in]	Outer diameter mm [in]	Static load radius mm [in]	Rolling circumference mm [in]	Tread depth mm [32nd]	Dual spacing mm [in]	Capacity liter [gal]	Measuring recommended rim	Other approved rims mm [in] <small>See end of document for more options</small>
6.00R9 121A5 TL	110206 68425	25 15.5	164 6.5	530 20.9	241 9.5	1605 63.2	10 12.6	192 7.6	18 4.8	4.00E	-

LOAD CAPACITY BASED ON INFLATION PRESSURE AND SPEED

Bar	Psi	6		8		10		145			
Machine - use kg - lbs											
COUNTERBALANCED LIFT TRUCK - STEER WHEEL											
STATIC		1590	3506			1890	4167			2190	4829
10 km/h	6 mph	1370	3021			1630	3594			1890	4167
25 km/h	15 mph	1050	2315			1250	2756			1450	3197
35 km/h	22 mph	980	2161			1160	2558			1350	2977
40 km/h	25 mph	940	2073			1120	2470			1300	2867
50 km/h	31 mph	890	1962			1050	2315			1220	2690
Machine - use kg - lbs											
COUNTERBALANCED LIFT TRUCK - LOAD WHEEL											
10 km/h	6 mph	1370	3021			1630	3594			1890	4167
25 km/h	15 mph	1370	3021			1630	3594			1890	4167
35 km/h	22 mph	1320	2911			1570	3462			1820	4013

MOUNTING ACCESSORIES	Recommended rim	Tubeless bead seal [CAI]	Rubber seal [CAI]	Tube [CAI]	Flap [CAI]
	4.00E	100TL9 [102151]	N/A	9F [368957]	125 - 9 [242079]

6.50R10 128A5 TL	110207 79365	25 15.5	184 7.2	578 22.8	264 10.4	1753 69	11 13.9	217 8.5	23 6.1	5.00F	5.50F
-------------------------	-----------------	------------	------------	-------------	-------------	------------	------------	------------	-----------	-------	-------

LOAD CAPACITY BASED ON INFLATION PRESSURE AND SPEED

Bar	Psi	6		8		10		145			
Machine - use kg - lbs											
COUNTERBALANCED LIFT TRUCK - STEER WHEEL											
STATIC		1930	4256			2310	5094			2720	5998
10 km/h	6 mph	1660	3660			1990	4388			2340	5160
25 km/h	15 mph	1280	2822			1530	3374			1800	3969
35 km/h	22 mph	1180	2602			1420	3131			1670	3682
40 km/h	25 mph	1140	2514			1360	2999			1610	3550
50 km/h	31 mph	1080	2381			1290	2844			1520	3352
Machine - use kg - lbs											
COUNTERBALANCED LIFT TRUCK - LOAD WHEEL											
10 km/h	6 mph	1660	3660			1990	4388			2340	5160
25 km/h	15 mph	1660	3660			1990	4388			2340	5160
35 km/h	22 mph	1600	3528			1910	4212			2250	4961

MOUNTING ACCESSORIES	Recommended rim	Tubeless bead seal [CAI]	Rubber seal [CAI]	Tube [CAI]	Flap [CAI]
	5.00E	125TL10 [102183]	N/A	10F [007946]	140 - 10 [001969]

TECHNICAL CHARACTERISTICS

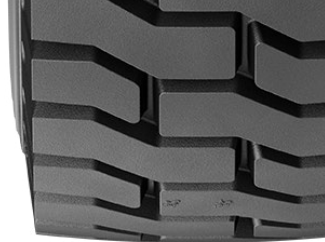

DESCRIPTION	CAI [MSPN]	Max.dist./ hour km [mile]	Section width mm [in]	Outer diameter mm [in]	Static load radius mm [in]	Rolling circumference mm [in]	Tread depth mm [32nd]	Dual spacing mm [in]	Capacity liter [gal]	Measuring recommended rim	Other approved rims mm [in] <small>See end of document for more options</small>
7.00R12 136A5 TL	110210 62234	25 15.5	193 7.6	661 26	302 11.9	2006 79	11 13.9	230 9.1	32 8.5	5.00S	-

LOAD CAPACITY BASED ON INFLATION PRESSURE AND SPEED

Bar *Psi* **6 87** **8 116** **10 145**

Machine - use kg - lbs COUNTERBALANCED LIFT TRUCK - STEER WHEEL

STATIC	2320	5116	2750	6064	3390	7475
10 km/h 6 mph	1990	4388	2370	5226	2920	6439
25 km/h 15 mph	1530	3374	1820	4013	2240	4939
35 km/h 22 mph	1420	3131	1690	3726	2080	4586
40 km/h 25 mph	1370	3021	1620	3572	2000	4410
50 km/h 31 mph	1290	2844	1530	3374	1890	4167

Machine - use kg - lbs COUNTERBALANCED LIFT TRUCK - LOAD WHEEL

10 km/h 6 mph	1990	4388	2370	5226	2920	6439
25 km/h 15 mph	1990	4388	2370	5226	2920	6439
35 km/h 22 mph	1920	4234	2280	5027	2800	6174

MOUNTING ACCESSORIES	Recommended rim	Tubeless bead seal [CAI]	Rubber seal [CAI]	Tube [CAI]	Flap [CAI]
	5.00S	125TL12 [522788]	N/A	12H [625614]	135 - 12 [190171]

MICHELIN XZM



1 TREADLIFE

Increase wear life: from +50% to +160% hours in operation ⁽¹⁾

Outstanding life performance is expected with the improved radial structure in addition to the deep and massive tread pattern.

2 ROBUSTNESS

Optimize machine uptime

The high resistant metallic crown belt structure and innovative tread pattern provide additional sidewall protection.

3 PRODUCTIVITY

Drive up to 15 km in an hour at 25 km/h ⁽²⁾

Radial technology is usually the best alternative for operations requiring more productivity with the transport of more tons per hour.

TIRE CHARACTERISTICS

ADDITIONAL INFORMATION



VEHICLE EQUIPMENT



AND MORE

The XZM's steel radial structure has been recognized by our customers for 30 years. Our customers are delighted with its durability, limited downtime and service value, even in the most demanding applications.

- Michelin Industrial and Port Tires Product Manager

⁽¹⁾ Field study in real life conditions made by Michelin for 2 years 2009-2011, on 60 forklifts in Europe (UK/Germany) same tire size and same usage on existing MICHELIN XZM range vs. premium competitors.

⁽²⁾ Distance per hour is directly correlated to the amount of tons transportable in an hour.

LEARN MORE

ON THE WEB
business.michelin.co.uk

TESTIMONIALS
youtube.com/michelinearthmover

TOOLS

BEYOND ROAD SELECTOR
beyond-road.selector.michelingroup.com/mh

CONTACT

Please contact your local sales representative for more information.

TECHNICAL CHARACTERISTICS

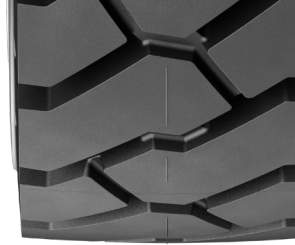

DESCRIPTION	CAI [MSPN]	Max.dist./ hour km [mile]	Section width mm [in]	Outer diameter mm [in]	Static load radius mm [in]	Rolling circumference mm [in]	Tread depth mm [32nd]	Dual spacing mm [in]	Capacity liter [gal]	Measuring recommended rim	Other approved rims mm [in] <small>See end of document for more options</small>
5.00R8 111A5 TL	110208 86381	15 9.3	137 5.4	463 18.2	212 8.3	1407 55.4	23 29	164 6.5	9 2.4	3.25I	3.00D 3.50D

LOAD CAPACITY BASED ON INFLATION PRESSURE AND SPEED

Bar	Psi	6		8		10		145			
Machine - use kg - lbs		COUNTERBALANCED LIFT TRUCK - STEER WHEEL									
STATIC		1230	2712			1420	3131			1650	3638
10 km/h	6 mp/h	1060	2337			1230	2712			1420	3131
25 km/h	15 mp/h	810	1786			940	2073			1090	2403
35 km/h	22 mp/h	750	1654			870	1918			1010	2227
Machine - use kg - lbs		COUNTERBALANCED LIFT TRUCK - LOAD WHEEL									
10 km/h	6 mp/h	1060	2337			1230	2712			1420	3131
25 km/h	15 mp/h	1060	2337			1230	2712			1420	3131
35 km/h	22 mp/h	1020	2249			1180	2602			1370	3021
MOUNTING ACCESSORIES		Recommended rim		Tubeless bead seal [CAI]		Rubber seal [CAI]		Tube [CAI]		Flap [CAI]	
		3.25I		80TL8 [102150]		N/A		8CG [566382]		90 - 8 [894130]	

150/75R8 113A5 TL	110087 55004	15 9.3	151 5.9	424 16.7	194 7.6	1287 50.7	16 20.2	174 6.9	8 2.1	4.33R	-
--------------------------	-----------------	-----------	------------	-------------	------------	--------------	------------	------------	----------	-------	---

LOAD CAPACITY BASED ON INFLATION PRESSURE AND SPEED

Bar	Psi	6		8		10		145			
Machine - use kg - lbs		COUNTERBALANCED LIFT TRUCK - STEER WHEEL									
STATIC		1240	2734			1480	3263			1740	3837
10 km/h	6 mp/h	1070	2359			1280	2822			1500	3308
25 km/h	15 mp/h	820	1808			980	2161			1150	2536
35 km/h	22 mp/h	760	1676			910	2007			1070	2359
Machine - use kg - lbs		COUNTERBALANCED LIFT TRUCK - LOAD WHEEL									
10 km/h	6 mp/h	1070	2359			1280	2822			1500	3308
25 km/h	15 mp/h	1070	2359			1280	2822			1500	3308
35 km/h	22 mp/h	1030	2271			1230	2712			1440	3175
MOUNTING ACCESSORIES		Recommended rim		Tubeless bead seal [CAI]		Rubber seal [CAI]		Tube [CAI]		Flap [CAI]	
		4.33R		110TL8 [613972]		-		8CG [566382]		90 - 8 [894130]	

TECHNICAL CHARACTERISTICS

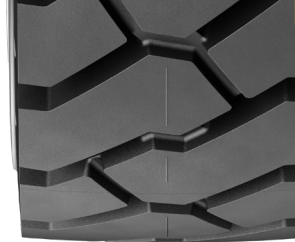

DESCRIPTION	CAI [MSPN]	Max.dist./ hour km [mile]	Section width mm [in]	Outer diameter mm [in]	Static load radius mm [in]	Rolling circumference mm [in]	Tread depth mm [32nd]	Dual spacing mm [in]	Capacity liter [gal]	Measuring recommended rim	Other approved rims mm [in] <small>See end of document for more options</small>
180/70R8 125A5 TL	110069 64585	15 9.3	170 6.7	454 17.9	205 8.1	1371 54	19 23.9	196 7.7	11 2.9	4.33R	-

LOAD CAPACITY BASED ON INFLATION PRESSURE AND SPEED

Bar	Psi	6		8		10	
Machine - use kg - lbs		COUNTERBALANCED LIFT TRUCK - STEER WHEEL					
STATIC		1890	4167	2190	4829	2500	5513
10 km/h	6 mp/h	1630	3594	1890	4167	2150	4741
25 km/h	15 mp/h	1250	2756	1450	3197	1650	3638
35 km/h	22 mp/h	1160	2558	1350	2977	1530	3374
Machine - use kg - lbs		COUNTERBALANCED LIFT TRUCK - LOAD WHEEL					
10 km/h	6 mp/h	1630	3594	1890	4167	2150	4741
25 km/h	15 mp/h	1630	3594	1890	4167	2150	4741
35 km/h	22 mp/h	1570	3462	1820	4013	2070	4564

MOUNTING ACCESSORIES	Recommended rim	Tubeless bead seal [CAI]	Rubber seal [CAI]	Tube [CAI]	Flap [CAI]
	4.33R	110TL8 [613972]	N/A	8D [964067]	90 - 8 [894130]

TECHNICAL CHARACTERISTICS

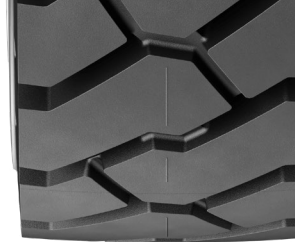

DESCRIPTION	CAI [MSPN]	Max.dist./ hour km [mile]	Section width mm [in]	Outer diameter mm [in]	Static load radius mm [in]	Rolling circumference mm [in]	Tread depth mm [32nd]	Dual spacing mm [in]	Capacity liter [gal]	Measuring recommended rim	Other approved rims mm [in] <small>See end of document for more options</small>
6.00R9 121A5 TL	110204 50734	15 9.3	164 6.5	539 21.2	248 9.8	1641 64.6	24 30.2	192 7.6	15 4	4.00E	-

LOAD CAPACITY BASED ON INFLATION PRESSURE AND SPEED

Bar	Psi	6		8		10		145			
Machine - use kg - lbs		COUNTERBALANCED LIFT TRUCK - STEER WHEEL									
STATIC		1590	3506			1890	4167			2190	4829
10 km/h	6 mp/h	1970	3021			1630	3594			1890	4167
25 km/h	15 mp/h	1050	2315			1250	2756			1450	3197
35 km/h	22 mp/h	980	2161			1160	2558			1350	2977
Machine - use kg - lbs		COUNTERBALANCED LIFT TRUCK - LOAD WHEEL									
10 km/h	6 mp/h	1370	3021			1630	3594			1890	4167
25 km/h	15 mp/h	1370	3021			1630	3594			1890	4167
35 km/h	22 mp/h	1320	2911			1570	3462			1820	4013

MOUNTING ACCESSORIES	Recommended rim	Tubeless bead seal [CAI]	Rubber seal [CAI]	Tube [CAI]	Flap [CAI]
	4.00E	100TL9 [102151]	N/A	9F [368957]	125 - 9 [242079]

200/75R9 134A5 TL	110090 79749	15 9.3	208 8.2	534 21	240 9.4	1610 63.4	22 27.7	239 9.4	19 5	6.00E	-
--------------------------	-----------------	-----------	------------	-----------	------------	--------------	------------	------------	---------	-------	---

LOAD CAPACITY BASED ON INFLATION PRESSURE AND SPEED

Bar	Psi	6		8		10		145			
Machine - use kg - lbs		COUNTERBALANCED LIFT TRUCK - STEER WHEEL									
STATIC		2270	5005			2750	6064			3210	7078
10 km/h	6 mp/h	1950	4300			2370	5226			2760	6086
25 km/h	15 mp/h	1500	3308			1820	4013			2120	4675
35 km/h	22 mp/h	1390	3065			1690	3726			1970	4344
Machine - use kg - lbs		COUNTERBALANCED LIFT TRUCK - LOAD WHEEL									
10 km/h	6 mp/h	1950	4300			2370	5226			2760	6086
25 km/h	15 mp/h	1950	4300			2370	5226			2760	6086
35 km/h	22 mp/h	1880	4145			2280	5027			2650	5843

MOUNTING ACCESSORIES	Recommended rim	Tubeless bead seal [CAI]	Rubber seal [CAI]	Tube [CAI]	Flap [CAI]
	6.00E	150TL9 [102182]	N/A	9F [368957]	180-9 [698290]

TECHNICAL CHARACTERISTICS

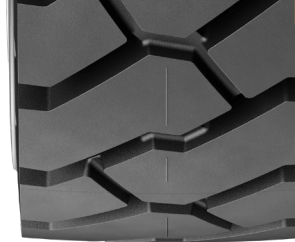

DESCRIPTION	CAI [MSPN]	Max.dist./ hour km [mile]	Section width mm [in]	Outer diameter mm [in]	Static load radius mm [in]	Rolling circumference mm [in]	Tread depth mm [32nd]	Dual spacing mm [in]	Capacity liter [gal]	Measuring recommended rim	Other approved rims mm [in] <small>See end of document for more options</small>
6.50R10 128A5 TL	110213 54636	15 9.3	186 7.3	587 23.1	270 10.6	1786 70.3	27 34	217 8.5	20 5.3	5.00F	5.50F

LOAD CAPACITY BASED ON INFLATION PRESSURE AND SPEED

Bar	Psi	6		8		10		145			
Machine - use kg - lbs		COUNTERBALANCED LIFT TRUCK - STEER WHEEL									
STATIC		1930	4256			2310	5094			2720	5998
10 km/h	6 mp/h	1660	3660			1990	4388			2340	5160
25 km/h	15 mp/h	1280	2822			1530	3374			1800	3969
35 km/h	22 mp/h	1180	2602			1420	3131			1670	3682
Machine - use kg - lbs		COUNTERBALANCED LIFT TRUCK - LOAD WHEEL									
10 km/h	6 mp/h	1660	3660			1990	4388			2340	5160
25 km/h	15 mp/h	1660	3660			1990	4388			2340	5160
35 km/h	22 mp/h	1600	3528			1910	4212			2250	4961

MOUNTING ACCESSORIES	Recommended rim	Tubeless bead seal [CAI]	Rubber seal [CAI]	Tube [CAI]	Flap [CAI]
	5.00F	125TL10 [102183]	N/A	10F [007946]	140 - 10 [001969]

225/75R10 142A5 TL	110089 59673	15 9.3	220 8.7	591 23.3	264 10.4	1779 70	24 30.2	259 10.2	25 6.6	6.50F	-
---------------------------	-----------------	-----------	------------	-------------	-------------	------------	------------	-------------	-----------	-------	---

LOAD CAPACITY BASED ON INFLATION PRESSURE AND SPEED

Bar	Psi	6		8		10		145			
Machine - use kg - lbs		COUNTERBALANCED LIFT TRUCK - STEER WHEEL									
STATIC		2800	6174			3430	7563			4010	8842
10 km/h	6 mp/h	2410	5314			2960	6527			3450	7607
25 km/h	15 mp/h	1850	4079			2270	5005			2650	5843
35 km/h	22 mp/h	1720	3793			2100	4631			2460	5424
Machine - use kg - lbs		COUNTERBALANCED LIFT TRUCK - LOAD WHEEL									
10 km/h	6 mp/h	2410	5314			2960	6527			3450	7607
25 km/h	15 mp/h	2410	5314			2960	6527			3450	7607
35 km/h	22 mp/h	2320	5116			2840	6262			3320	7321

MOUNTING ACCESSORIES	Recommended rim	Tubeless bead seal [CAI]	Rubber seal [CAI]	Tube [CAI]	Flap [CAI]
	6.50F	165TL10 [102114]	N/A	10F [007946]	140 - 10 [001969]

TECHNICAL CHARACTERISTICS

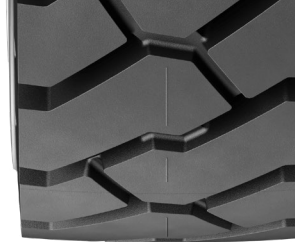

DESCRIPTION	CAI [MSPN]	Max.dist./ hour km [mile]	Section width mm [in]	Outer diameter mm [in]	Static load radius mm [in]	Rolling circumference mm [in]	Tread depth mm [32nd]	Dual spacing mm [in]	Capacity liter [gal]	Measuring recommended rim	Other approved rims mm [in] <small>See end of document for more options</small>
7.00R12 136A5 TL	110195 71359	15 9.3	196 7.7	671 26.4	309 12.2	2043 80.4	28 35.3	230 9.1	24 6.3	5.00S	-

LOAD CAPACITY BASED ON INFLATION PRESSURE AND SPEED

Bar	Psi	6		8		10		145			
Machine - use kg - lbs		COUNTERBALANCED LIFT TRUCK - STEER WHEEL									
STATIC		2320	5116			2750	6064			3390	7475
10 km/h	6 mp/h	1990	4388			2370	5226			2920	6439
25 km/h	15 mp/h	1530	3374			1820	4013			2240	4939
35 km/h	22 mp/h	1420	3131			1690	3726			2080	4586
Machine - use kg - lbs		COUNTERBALANCED LIFT TRUCK - LOAD WHEEL									
10 km/h	6 mp/h	1990	4388			2370	5226			2920	6439
25 km/h	15 mp/h	1990	4388			2370	5226			2920	6439
35 km/h	22 mp/h	1920	4234			2280	5027			2800	6174

MOUNTING ACCESSORIES	Recommended rim	Tubeless bead seal [CAI]	Rubber seal [CAI]	Tube [CAI]	Flap [CAI]
	5.00S	125TL12 [522788]	N/A	12H [625614]	135 - 12 [190171]

250/60R12 145A5 TL	358151 07263	15 9.3	254 10	616 24.3	280 11	1865 73.4	27 34	293 11.5	30 7.9	8.00G	-
---------------------------	-----------------	-----------	-----------	-------------	-----------	--------------	----------	-------------	-----------	-------	---

LOAD CAPACITY BASED ON INFLATION PRESSURE AND SPEED

Bar	Psi	6		8		10		145			
Machine - use kg - lbs		COUNTERBALANCED LIFT TRUCK - STEER WHEEL									
STATIC		3060	6747			3700	8159			4380	9658
10 km/h	6 mp/h	2640	5821			3190	7034			3770	8313
25 km/h	15 mp/h	2030	4476			2450	5402			2900	6395
35 km/h	22 mp/h	1880	4145			2270	5005			2690	5931
Machine - use kg - lbs		COUNTERBALANCED LIFT TRUCK - LOAD WHEEL									
10 km/h	6 mp/h	2640	5821			3930	8666			4620	10187
25 km/h	15 mp/h	2640	5821			3930	8666			4620	10187
35 km/h	22 mp/h	2540	5601			3780	8335			4440	9790

MOUNTING ACCESSORIES	Recommended rim	Tubeless bead seal [CAI]	Rubber seal [CAI]	Tube [CAI]	Flap [CAI]
	8.00G	200TL12 [787198]	N/A	12H [625614]	210 - 12 [030440]

TECHNICAL CHARACTERISTICS

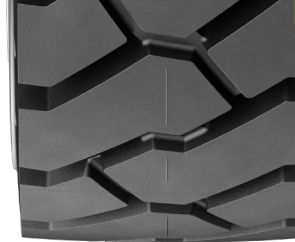

DESCRIPTION	CAI [MSPN]	Max.dist./ hour km [mile]	Section width mm [in]	Outer diameter mm [in]	Static load radius mm [in]	Rolling circumference mm [in]	Tread depth mm [32nd]	Dual spacing mm [in]	Capacity liter [gal]	Measuring recommended rim	Other approved rims mm [in] <small>See end of document for more options</small>
250/75R12 152A5 TL	110108 51744	15 9.3	256 10.1	688 27.1	311 12.2	2078 81.8	28 35.3	294 11.6	38 10	8.00G	-

LOAD CAPACITY BASED ON INFLATION PRESSURE AND SPEED

Bar	Psi	6				8				10			
		87				116				145			
Machine - use kg - lbs		COUNTERBALANCED LIFT TRUCK - STEER WHEEL											
STATIC		3730 8225				4570 10077				5370 11841			
10 km/h	6 mp/h	3220 7100				3930 8666				4620 10187			
25 km/h	15 mp/h	2470 5446				3020 6659				3550 7828			
35 km/h	22 mp/h	2290 5049				2800 6174				3290 7254			
Machine - use kg - lbs		COUNTERBALANCED LIFT TRUCK - LOAD WHEEL											
10 km/h	6 mp/h	3220 7100				3930 8666				4620 10187			
25 km/h	15 mp/h	3220 7100				3930 8666				4620 10187			
35 km/h	22 mp/h	3090 6813				3780 8335				4440 9790			
MOUNTING ACCESSORIES		Recommended rim		Tubeless bead seal [CAI]		Rubber seal [CAI]		Tube [CAI]		Flap [CAI]			
		8.00G		200TL12 [787198]		N/A		12KD [188148]		210 - 12 [030440]			

TECHNICAL CHARACTERISTICS

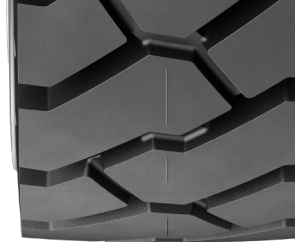

DESCRIPTION	CAI [MSPN]	Max.dist./ hour km [mile]	Section width mm [in]	Outer diameter mm [in]	Static load radius mm [in]	Rolling circumference mm [in]	Tread depth mm [32nd]	Dual spacing mm [in]	Capacity liter [gal]	Measuring recommended rim	Other approved rims mm [in] <small>See end of document for more options</small>
7.00R15 143A5 TL	110211 85869	15 9.3	196 7.7	733 28.9	337 13.3	2230 87.8	28 35.3	235 9.3	30 7.9	5.5	6.0

LOAD CAPACITY BASED ON INFLATION PRESSURE AND SPEED

Bar	Psi	6		8		10		145			
Machine - use kg - lbs		COUNTERBALANCED LIFT TRUCK - STEER WHEEL									
STATIC		3075	6780			3600	7938			4090	9018
10 km/h	6 mp/h	2665	5876			3120	6880			3540	7806
25 km/h	15 mp/h	2050	4520			2400	5292			2725	6009
35 km/h	22 mp/h	1895	4178			2220	4895			2520	5557
Machine - use kg - lbs		COUNTERBALANCED LIFT TRUCK - LOAD WHEEL									
10 km/h	6 mp/h	2665	5876			3120	6880			3540	7806
25 km/h	15 mp/h	2665	5876			3120	6880			3540	7806
35 km/h	22 mp/h	2560	5645			3000	6615			3405	7508

MOUNTING ACCESSORIES	Recommended rim	Tubeless bead seal [CAI]	Rubber seal [CAI]	Tube [CAI]	Flap [CAI]
	5.5	140TL15 [454346]	N/A	7.00 - 15 / 7.50 - 15 [812339]	180 - 15 [670236]

7.50R15 146A5 TL	110214 62488	15 9.3	212 8.3	771 30.4	357 14.1	2352 92.6	30 37.8	254 10	38 10	6.0	6.5
-------------------------	-----------------	-----------	------------	-------------	-------------	--------------	------------	-----------	----------	-----	-----

LOAD CAPACITY BASED ON INFLATION PRESSURE AND SPEED

Bar	Psi	6		8		10		145			
Machine - use kg - lbs		COUNTERBALANCED LIFT TRUCK - STEER WHEEL									
STATIC		3300	7277			3930	8666			4530	9989
10 km/h	6 mp/h	2840	6262			3380	7453			3900	8600
25 km/h	15 mp/h	2180	4807			2600	5733			3000	6615
35 km/h	22 mp/h	2020	4454			2410	5314			2780	6130
Machine - use kg - lbs		COUNTERBALANCED LIFT TRUCK - LOAD WHEEL									
10 km/h	6 mp/h	2840	6262			3380	7453			3900	8600
25 km/h	15 mp/h	2840	6262			3380	7453			3900	8600
35 km/h	22 mp/h	2730	6020			3250	7166			3750	8269

MOUNTING ACCESSORIES	Recommended rim	Tubeless bead seal [CAI]	Rubber seal [CAI]	Tube [CAI]	Flap [CAI]
	6.0	150TL15 [702507]	N/A	7.00 - 15 / 7.50 - 15 [812339]	180 - 15 [670236]

TECHNICAL CHARACTERISTICS

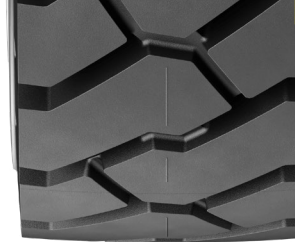

DESCRIPTION	CAI [MSPN]	Max.dist./ hour km [mile]	Section width mm [in]	Outer diameter mm [in]	Static load radius mm [in]	Rolling circumference mm [in]	Tread depth mm [32nd]	Dual spacing mm [in]	Capacity liter [gal]	Measuring recommended rim	Other approved rims mm [in] <small>See end of document for more options</small>
8.25R15 153A5 TL	110218 56370	15 9.3	240 9.4	835 32.9	385 15.2	2543 100.1	33 41.6	280 11	46 12.2	6.5	7.0 7.5

LOAD CAPACITY BASED ON INFLATION PRESSURE AND SPEED

Bar	Psi	6		8		10		145			
Machine - use kg - lbs											
COUNTERBALANCED LIFT TRUCK - STEER WHEEL											
STATIC		4010	8842			4760	10496			5520	12172
10 km/h	6 mp/h	3450	7607			4100	9041			4750	10474
25 km/h	15 mp/h	2650	5843			3150	6946			3650	8048
35 km/h	22 mp/h	2460	5424			2920	6439			3380	7453
Machine - use kg - lbs											
COUNTERBALANCED LIFT TRUCK - LOAD WHEEL											
10 km/h	6 mp/h	3450	7607			4100	9041			4750	10474
25 km/h	15 mp/h	3450	7607			4100	9041			4750	10474
35 km/h	22 mp/h	3320	7321			3940	8688			4570	10077

MOUNTING ACCESSORIES	Recommended rim	Tubeless bead seal [CAI]	Rubber seal [CAI]	Tube [CAI]	Flap [CAI]
	6.5	165TL15 [575769]	N/A	8.25 - 15 [694949]	180 - 15 [670236]

225/75R15 149A5 TL	110079 55324	15 9.3	225 8.9	708 27.9	322 12.7	2144 84.4	25 31.5	259 10.2	34 9	7.0	-
---------------------------	-----------------	-----------	------------	-------------	-------------	--------------	------------	-------------	---------	-----	---

LOAD CAPACITY BASED ON INFLATION PRESSURE AND SPEED

Bar	Psi	6		8		10		145			
Machine - use kg - lbs											
COUNTERBALANCED LIFT TRUCK - STEER WHEEL											
STATIC		3480	7673			4230	9327			4910	10827
10 km/h	6 mp/h	2990	6593			3640	8026			4230	9327
25 km/h	15 mp/h	2300	5072			2800	6174			3250	7166
35 km/h	22 mp/h	2130	4697			2590	5711			3010	6637
Machine - use kg - lbs											
COUNTERBALANCED LIFT TRUCK - LOAD WHEEL											
10 km/h	6 mp/h	2990	6593			3640	8026			4230	9327
25 km/h	15 mp/h	2990	6593			3640	8026			4230	9327
35 km/h	22 mp/h	2880	6350			3500	7718			4070	8974

MOUNTING ACCESSORIES	Recommended rim	Tubeless bead seal [CAI]	Rubber seal [CAI]	Tube [CAI]	Flap [CAI]
	7.0	175TL15 [260511]	N/A	7.00 - 15 / 7.50 - 15 [812339]	180 - 15 [670236]

TECHNICAL CHARACTERISTICS

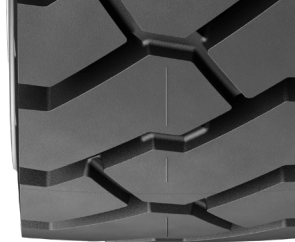

DESCRIPTION	CAI [MSPN]	Max.dist./ hour km [mile]	Section width mm [in]	Outer diameter mm [in]	Static load radius mm [in]	Rolling circumference mm [in]	Tread depth mm [32nd]	Dual spacing mm [in]	Capacity liter [gal]	Measuring recommended rim	Other approved rims mm [in] <small>See end of document for more options</small>
250/70R15 153A5 TL	110075 50988	15 9.3	250 9.8	736 29	333 13.1	2224 87.6	28 35.3	288 11.3	39 10.3	7.5	7.0

LOAD CAPACITY BASED ON INFLATION PRESSURE AND SPEED

Bar	Psi	6		8		10	
		87		116		145	
Machine - use kg - lbs							
COUNTERBALANCED LIFT TRUCK - STEER WHEEL							
STATIC		3780	8335	4670	10297	5520	12172
10 km/h	6 mp/h	3250	7166	4020	8864	4750	10474
25 km/h	15 mp/h	2500	5513	3090	6813	3650	8048
35 km/h	22 mp/h	2320	5116	2860	6306	3380	7453
Machine - use kg - lbs							
COUNTERBALANCED LIFT TRUCK - LOAD WHEEL							
10 km/h	6 mp/h	3250	7166	4020	8864	4750	10474
25 km/h	15 mp/h	3250	7166	4020	8864	4750	10474
35 km/h	22 mp/h	3130	6902	3870	8533	4570	10077

MOUNTING ACCESSORIES	Recommended rim	Tubeless bead seal [CAI]	Rubber seal [CAI]	Tube [CAI]	Flap [CAI]
	7.5	190TL15 [464164]	N/A	7.00 - 15 / 7.50 - 15 [812339]	180 - 15 [670236]

315/70R15 165A5 TL	110109 85047	15 9.3	321 12.6	839 33	373 14.7	2520 99.2	35 44.1	369 14.5	74 19.6	8.0	-
---------------------------	-----------------	-----------	-------------	-----------	-------------	--------------	------------	-------------	------------	-----	---

LOAD CAPACITY BASED ON INFLATION PRESSURE AND SPEED

Bar	Psi	6		8		10	
		87		116		145	
Machine - use kg - lbs							
COUNTERBALANCED LIFT TRUCK - STEER WHEEL							
STATIC		5370	11841	6570	14487	7780	17155
10 km/h	6 mp/h	4620	10187	5660	12480	6700	14774
25 km/h	15 mp/h	3550	7828	4350	9592	5150	11356
35 km/h	22 mp/h	3290	7254	4030	8886	4770	10518
Machine - use kg - lbs							
COUNTERBALANCED LIFT TRUCK - LOAD WHEEL							
10 km/h	6 mp/h	4620	10187	5660	12480	6700	14774
25 km/h	15 mp/h	4620	10187	5660	12480	6700	14774
35 km/h	22 mp/h	4440	9790	5440	11995	6440	14200

MOUNTING ACCESSORIES	Recommended rim	Tubeless bead seal [CAI]	Rubber seal [CAI]	Tube [CAI]	Flap [CAI]
	8.0	200TL15 [609679]	N/A	8.25 - 15 [694949]	260 - 15 [751612]

TECHNICAL CHARACTERISTICS

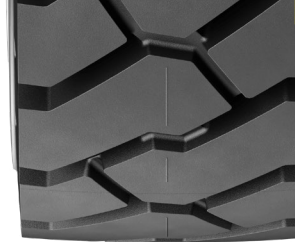

DESCRIPTION	CAI [MSPN]	Max.dist./ hour km [mile]	Section width mm [in]	Outer diameter mm [in]	Static load radius mm [in]	Rolling circumference mm [in]	Tread depth mm [32nd]	Dual spacing mm [in]	Capacity liter [gal]	Measuring recommended rim	Other approved rims mm [in] <small>See end of document for more options</small>
355/65R15 170A5 TL	003789 81758	15 9.3	355 14	842 33.1	376 14.8	2532 99.7	35 44.1	408 16.1	83 21.9	9.75	-

LOAD CAPACITY BASED ON INFLATION PRESSURE AND SPEED

Bar	Psi	6				8				10			
		87				116				145			
Machine - use kg - lbs		COUNTERBALANCED LIFT TRUCK - STEER WHEEL											
STATIC		6190 13649				7630 16824				9060 19977			
10 km/h	6 mp/h	5330 11753				6565 14476				7800 17199			
25 km/h	15 mp/h	4100 9041				5050 11135				6000 13230			
35 km/h	22 mp/h	3800 8379				4670 10297				5550 12238			
Machine - use kg - lbs		COUNTERBALANCED LIFT TRUCK - LOAD WHEEL											
10 km/h	6 mp/h	5330 11753				6565 14476				7800 17199			
25 km/h	15 mp/h	5330 11753				6565 14476				7800 17199			
35 km/h	22 mp/h	5130 11312				6310 13914				7500 16538			
MOUNTING ACCESSORIES		Recommended rim		Tubeless bead seal [CAI]		Rubber seal [CAI]		Tube [CAI]		Flap [CAI]			
		9.75		250TL15 [026320]		N/A		N/A		N/A			

TECHNICAL CHARACTERISTICS

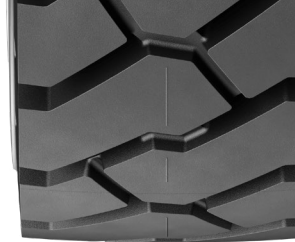

DESCRIPTION	CAI [MSPN]	Max.dist./ hour km [mile]	Section width mm [in]	Outer diameter mm [in]	Static load radius mm [in]	Rolling circumference mm [in]	Tread depth mm [32nd]	Dual spacing mm [in]	Capacity liter [gal]	Measuring recommended rim	Other approved rims mm [in] <i>See end of document for more options</i>
9.00R20 160A5 TL	110185 87259	15 9.3	271 10.7	1033 40.7	481 18.9	3157 124.3	33 41.6	325 12.8	99 26.2	7.0	6.5, 7.0T, 7.33V, 7.5, B6.5, B7.5, B7.0

LOAD CAPACITY BASED ON INFLATION PRESSURE AND SPEED

Bar Psi 6 87 8 116 10 145

Machine - use
kg - lbs

COUNTERBALANCED LIFT TRUCK - STEER WHEEL

STATIC		4840	10672			5800	12789			6800	14994
10 km/h	6 mp/h	4160	9173			5000	11025			5850	12899
25 km/h	15 mp/h	3200	7056			3840	8467			4500	9923
35 km/h	22 mp/h	2970	6549			3560	7850			4170	9195
40 km/h	25 mp/h	2850	6284			3420	7541			4010	8842

Machine - use
kg - lbs

COUNTERBALANCED LIFT TRUCK - LOAD WHEEL

10 km/h	6 mp/h	4160	9173			5000	11025			5850	12899
25 km/h	15 mp/h	4160	9173			5000	11025			5850	12899
35 km/h	22 mp/h	4000	8820			4800	10584			5620	12392

MOUNTING ACCESSORIES	Recommended rim	Tubeless bead seal [CAI]	Rubber seal [CAI]	Tube [CAI]	Flap [CAI]
	7.0	175TL20 [102087]	A20 [553004]	8.25 - 20 [437622]	185 - 20 [907771]

10.00R20 166A5 TL	110014 42890	15 9.3	295 11.6	1068 42	495 19.5	3257 128.2	35 44.1	354 13.9	117 30.9	7.5	7.0, 7.0T, 7.33V, 8.0, 8.00V, 8.0V, B7.0, B7.5, B8.0
--------------------------	-----------------	-----------	-------------	------------	-------------	---------------	------------	-------------	-------------	-----	--

LOAD CAPACITY BASED ON INFLATION PRESSURE AND SPEED

Bar Psi 6 87 8 116 10 145

Machine - use
kg - lbs

COUNTERBALANCED LIFT TRUCK - STEER WHEEL

STATIC		5740	12657			6850	15104			8010	17662
10 km/h	6 mp/h	4940	10893			5890	12987			6890	15192
25 km/h	15 mp/h	3800	8379			4530	9989			5300	11687
35 km/h	22 mp/h	3520	7762			4200	9261			4910	10827
40 km/h	25 mp/h	3390	7475			4040	8908			4720	10408

Machine - use
kg - lbs

COUNTERBALANCED LIFT TRUCK - LOAD WHEEL

10 km/h	6 mp/h	4940	10893			5890	12987			6890	15192
25 km/h	15 mp/h	4940	10893			5890	12987			6890	15192
35 km/h	22 mp/h	4750	10474			5660	12480			6630	14619

MOUNTING ACCESSORIES	Recommended rim	Tubeless bead seal [CAI]	Rubber seal [CAI]	Tube [CAI]	Flap [CAI]
	7.5	190TL20 [102083]	A20 [553004]	9.00 - 20 [052341]	200 - 20 [299014]

TECHNICAL CHARACTERISTICS

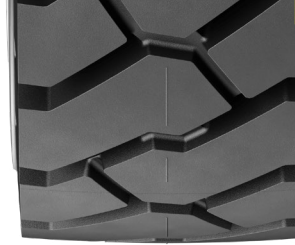

DESCRIPTION	CAI [MSPN]	Max. dist./ hour km [mile]	Section width mm [in]	Outer diameter mm [in]	Static load radius mm [in]	Rolling circumference mm [in]	Tread depth mm [32nd]	Dual spacing mm [in]	Capacity liter [gal]	Measuring recommended rim	Other approved rims mm [in] <small>See end of document for more options</small>
11.00R20 169A5 TL	110189 74767	15 9.3	294 11.6	1092 43	504 19.8	3325 130.9	38 47.9	353 13.9	124 32.8	8.0	7.33V, 7.5, 8.00V, 8.0V, 8.5, 8.50V, 8.5V, B7.5, B8.0, B8.5

LOAD CAPACITY BASED ON INFLATION PRESSURE AND SPEED

Bar	Psi	6 87				8 116				10 145	
Machine - use kg - lbs		COUNTERBALANCED LIFT TRUCK - STEER WHEEL									
STATIC		6260	13803			7510	16560			8760	19316
10 km/h	6 mp/h	5390	11885			6470	14266			7540	16626
25 km/h	15 mp/h	4140	9129			4970	10959			5800	12789
35 km/h	22 mp/h	3830	8445			4600	10143			5370	11841
40 km/h	25 mp/h	3690	8136			4430	9768			5170	11400
Machine - use kg - lbs		COUNTERBALANCED LIFT TRUCK - LOAD WHEEL									
10 km/h	6 mp/h	5390	11885			6470	14266			7540	16626
25 km/h	15 mp/h	5390	11885			6470	14266			7540	16626
35 km/h	22 mp/h	5180	11422			6220	13715			7250	15986
MOUNTING ACCESSORIES		Recommended rim	Tubeless bead seal [CAI]		Rubber seal [CAI]		Tube [CAI]		Flap [CAI]		
		8.0	200TL20 [102085]		A20 [553004]		10.00 - 20 [300462]		200 - 20 [299014]		

12.00R20 176A5 TL	110082 78891	15 9.3	324 12.8	1136 44.7	522 20.6	3453 135.9	40 50.4	389 15.3	184 48.6	8.5	8.0, 8.50V, 8.5V, 9.0, 9.00V, B8.5
--------------------------	-----------------	-----------	-------------	--------------	-------------	---------------	------------	-------------	-------------	-----	---------------------------------------

LOAD CAPACITY BASED ON INFLATION PRESSURE AND SPEED

Bar	Psi	6 87				8 116				10 145	
Machine - use kg - lbs		COUNTERBALANCED LIFT TRUCK - STEER WHEEL									
STATIC		7710	17001			9220	20330			10730	23660
10 km/h	6 mp/h	6630	14619			7930	17486			9230	20352
25 km/h	15 mp/h	5100	11246			6100	13451			7100	15656
35 km/h	22 mp/h	4720	10408			5650	12458			6570	14487
40 km/h	25 mp/h	4540	10011			5430	11973			6320	13936
Machine - use kg - lbs		COUNTERBALANCED LIFT TRUCK - LOAD WHEEL									
10 km/h	6 mp/h	6630	14619			7930	17486			9230	20352
25 km/h	15 mp/h	6630	14619			7930	17486			9230	20352
35 km/h	22 mp/h	6380	14068			7630	16824			8880	19580
MOUNTING ACCESSORIES		Recommended rim	Tubeless bead seal [CAI]		Rubber seal [CAI]		Tube [CAI]		Flap [CAI]		
		8.5	215TL20 [102086]		A20 [553004]		11.00 - 20 / 12.00 - 20 [179572]		200 - 20 [299014]		

TECHNICAL CHARACTERISTICS

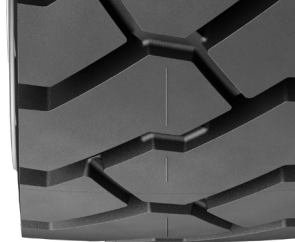

DESCRIPTION	CAI [MSPN]	Max.dist./ hour km [mile]	Section width mm [in]	Outer diameter mm [in]	Static load radius mm [in]	Rolling circumference mm [in]	Tread depth mm [32nd]	Dual spacing mm [in]	Capacity liter [gal]	Measuring recommended rim	Other approved rims mm [in] <small>See end of document for more options</small>
12.00R24 178A5 TL	110296 42105	15 9.3	325 12.8	1238 48.7	570 22.4	3766 148.3	40 50.4	390 15.4	208 55	8.5	8.50V, 9.0, 9.00V, B8.5

LOAD CAPACITY BASED ON INFLATION PRESSURE AND SPEED

Bar	Psi	6		8		10		145			
Machine - use kg - lbs											
COUNTERBALANCED LIFT TRUCK - STEER WHEEL											
STATIC		7710	17001			9520	20992			11330	24983
10 km/h	6 mp/h	6630	14619			8190	18059			9750	21499
25 km/h	15 mp/h	5100	11246			6300	13892			7500	16538
35 km/h	22 mp/h	4720	10408			5830	12855			6940	15303
Machine - use kg - lbs											
COUNTERBALANCED LIFT TRUCK - LOAD WHEEL											
10 km/h	6 mp/h	6630	14619			8190	18059			9750	21499
25 km/h	15 mp/h	6630	14619			8190	18059			9750	21499
35 km/h	22 mp/h	6380	14068			7880	17375			9380	20683

MOUNTING ACCESSORIES	Recommended rim	Tubeless bead seal [CAI]	Rubber seal [CAI]	Tube [CAI]	Flap [CAI]
	8.5	N/A	G25 (R1237) [553012]	325/95R24 [470853]	250 - 24 [025752]

14.00R24 193A5 TL	084179 93269	15 9.3	383 15.1	1416 55.7	641 25.2	4280 168.5	63 79.4	465 18.1	247 65.3	10.0	10.00W, 10.00WA
--------------------------	-----------------	-----------	-------------	--------------	-------------	---------------	------------	-------------	-------------	------	--------------------

LOAD CAPACITY BASED ON INFLATION PRESSURE AND SPEED

Bar	Psi	6		8		10		145			
Machine - use kg - lbs											
COUNTERBALANCED LIFT TRUCK - STEER WHEEL											
STATIC		12540	27651			15100	33296			17370	38301
10 km/h	6 mp/h	10790	23792			13000	28665			14950	32965
25 km/h	15 mp/h	8300	18302			10000	22050			11500	25358
Machine - use kg - lbs											
COUNTERBALANCED LIFT TRUCK - LOAD WHEEL											
10 km/h	6 mp/h	10790	23792			13000	28665			14950	32965
25 km/h	15 mp/h	10790	23792			13000	28665			14950	32965

MOUNTING ACCESSORIES	Recommended rim	Tubeless bead seal [CAI]	Rubber seal [CAI]	Tube [CAI]	Flap [CAI]
	10.0	N/A	OR 3-25 SULLA [553200]	24/25t [628804]	250 - 24 [025752]

TECHNICAL CHARACTERISTICS

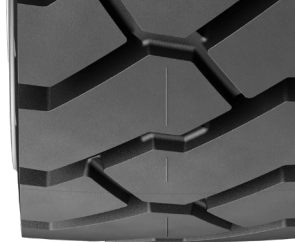

DESCRIPTION	CAI [MSPN]	Max.dist./ hour km [mile]	Section width mm [in]	Outer diameter mm [in]	Static load radius mm [in]	Rolling circumference mm [in]	Tread depth mm [32nd]	Dual spacing mm [in]	Capacity liter [gal]	Measuring recommended rim	Other approved rims mm [in] <small>See end of document for more options</small>
16.00R25 200A5 TL	123781 61590	15 9.3	443 17.4	1531 60.3	695 27.4	4634 182.4	71 89.4	532 20.9	326 86.1	11.25/2.0	13.00/2.0

LOAD CAPACITY BASED ON INFLATION PRESSURE AND SPEED

Bar	Psi	6		8		10			
		87		116		145			
Machine - use kg - lbs		COUNTERBALANCED LIFT TRUCK - STEER WHEEL							
STATIC		15600	34398	18225	40186	21000	46305		
10 km/h	6 mp/h	13520	29812	15800	34839	18200	40131		
25 km/h	15 mp/h	10400	22932	12150	26791	14000	30870		
Machine - use kg - lbs		COUNTERBALANCED LIFT TRUCK - LOAD WHEEL							
10 km/h	6 mp/h	13520	29812	15800	34839	18200	40131		
25 km/h	15 mp/h	13520	29812	15800	34839	18200	40131		
MOUNTING ACCESSORIES	Recommended rim	Tubeless bead seal [CAI]		Rubber seal [CAI]		Tube [CAI]		Flap [CAI]	
		11.25/2.0		N/A		OR 3-25 SULLA [553200]		N/A	

MICHELIN XZM 2+



1 TREADLIFE

15% longer service life ⁽¹⁾

The combination of massive tread pattern with a low abrasion rubber compound optimizes wear resistance and provides longer tire life.

2 ROBUSTNESS

Maximize machine uptime with high resistance to impact and puncture

The IND-5 technology improves the tire structure and offers additional sidewall protection.

3 PRODUCTIVITY

Drive up to 10 km in an hour at 25 km/h ⁽²⁾

Radial technology is usually the best alternative for operations requiring more productivity with the transport of more tons per hour.

TIRE CHARACTERISTICS



ADDITIONAL INFORMATION

VEHICLE EQUIPMENT



The XZM2+ range has been developed to offer more robustness and to maximize productivity. It remains a highly versatile solution for reach stacker, providing longer operating life.

- Michelin Industrial and Port
Tires Product Manager

⁽¹⁾ Compared with the same sized Michelin XZM tire under normal use.

⁽²⁾ Distance per hour is directly correlated to the amount of tons transportable in an hour.

LEARN MORE

ON THE WEB
business.michelin.co.uk

TESTIMONIALS
youtube.com/michelinearthmover

TOOLS

BEYOND ROAD SELECTOR
beyond-road.selector.michelingroup.com/mh

CONTACT

Please contact your local sales representative for more information.

MICHELIN X STACKER 2



1 TREADLIFE

7% more wear life ⁽¹⁾
The unique Michelin Dual Compound delivers longer lasting tires.

2 ROBUSTNESS

Excellent wheel interface
Introduction of the new Michelin B²® technology, which evenly distributes tire pressure on the rim.

3 PRODUCTIVITY

Drive up to 7 km in an hour at 25 km/h ⁽²⁾
Radial technology is usually the best alternative for operations requiring more productivity with the transport of more tons per hour.

TIRE CHARACTERISTICS



ADDITIONAL INFORMATION

VEHICLE EQUIPMENT



The X STACKER 2 delivers impressive hourly performance. This smooth IND5 radial tire offers extra life especially for stacking operations. It provides exceptional robustness and remarkable resistance to aggression.

- Michelin Industrial and Port
Tires Product Manager

⁽¹⁾ Compared to Michelin X STACKER 18.00R25 tire based on field service evaluation, 2013-2014, in customer port sites; same size and usages.

⁽²⁾ Compared to Michelin X STACKER 18.00R25 tire. Distance per hour is directly correlated to the amount of tons transportable in an hour.

LEARN MORE

ON THE WEB
business.michelin.co.uk

TESTIMONIALS
youtube.com/michelinearthmover

TOOLS

BEYOND ROAD SELECTOR
beyond-road.selector.michelingroup.com/mh

CONTACT

Please contact your local sales representative for more information.

MICHELIN X STACKER 3 HD



1 ROBUSTNESS

Extra service life in heavy duty conditions ⁽¹⁾

Radial structure optimized to endure heavy duty cycles.

2 PRODUCTIVITY

Drive up to 12 km in an hour at 25 km/h ⁽²⁾

Radial technology is usually the best alternative for operations requiring more productivity with the transport of more tons per hour.

3 TREADLIFE

Reduce downtime with reliable wear life projection ⁽³⁾

Tread wear indicator is now optimized to secure wear life projection and allows to plan the maintenance accordingly.

TIRE CHARACTERISTICS



ADDITIONAL INFORMATION

VEHICLE EQUIPMENTS



Port operators with wide fleets of several reach stackers often operate under tough conditions of load and speed to meet their productivity challenges. Their concern is unexpected machine downtime and they are specifically looking for tires that can help meet these challenges.

- Michelin Industrial and Port Tires Product Manager

⁽¹⁾ Compared to XZM2+ and XZM2+A that may be removed with 40% rubber remaining under severe condition. X STACKER 3 HD removed after being 100% worn, resulting in up to 30% extra life time. Data based on quality records, obtained from port operators, between 2017 and 2022.

⁽²⁾ Compared to MICHELIN® 18.00R25 XZM2+ and X STACKER 2 : respective max distance of 10 and 7 km in one hour at 25 km/h max speed. Distance per hour is directly correlated to the amount of tons transportable in an hour.

⁽³⁾ Compared to MICHELIN® 18.00R25 XZM2+/XZM2+A and X STACKER 2 LC. Field study in real life conditions made by Michelin during 7 years in a representative panel of operating terminals in Australia, Europe and Middle East; same size and usages.

LEARN MORE

ON THE WEB
business.michelin.co.uk

TESTIMONIALS
youtube.com/michelinearthmover

TOOLS

BEYOND ROAD SELECTOR
beyond-road.selector.michelingroup.com/mh

CONTACT

Please contact your local sales representative for more information.

MICHELIN X STRADDLE 2



1 TREADLIFE

15% more wear life ⁽¹⁾
The massive tread design with 8% more rubber insure the longest tire life.

2 LOAD CAPACITY

Carry up to 18 tons per tire ⁽²⁾
Due to an addition of 20% tire inner air volume.

3 PRODUCTIVITY

Drive up to 15 km in an hour at 25 km/h ⁽³⁾
Radial technology is usually the best alternative for operations requiring more productivity with the transport of more tons per hour.

TIRE CHARACTERISTICS

ADDITIONAL INFORMATION



VEHICLE EQUIPMENT



The X STRADDLE 2 range offers remarkable performance and proven reliability for over ten years. The X STRADDLE 2 CC version ensures intense usage up to 17 km in an hour and 55°C ⁽⁴⁾, while reducing rolling resistance by 20% ⁽⁵⁾ for greater efficiency.

- Michelin Port Tires
Product Manager

⁽¹⁾ Average performance measured by port location between 2008-2012. Predicted tire life improvement based on customer port field performance of MICHELIN X STRADDLE 2 450/95 R 25 vs. MICHELIN X STRADDLE 16.00 R 25.

⁽²⁾ At a nominal pressure of 10 bar, the tire model MICHELIN X STRADDLE 2 480/95 R 25 208 A5 can carry up to 18 tons compared to the tire model 450/95 R 25 204 A5.

⁽³⁾ Applicable to MICHELIN X STRADDLE 2 sizes 450 and 480.

⁽⁴⁾ The maximum distance traveled per hour for the MICHELIN X STRADDLE 2 of the same size is 15km/h at 38°C (12km at 55°C). The maximum distance traveled per hour for the MICHELIN X STRADDLE 2 CC of the same size is 17km/h at 38°C (15 km at 55°C).

⁽⁵⁾ Comparison between the MICHELIN X STRADDLE 2 480/95 R25 and the X STRADDLE CC of the same dimension, based on Michelin's rolling resistance laboratory measurements conducted under defined loads and speeds that are representative of operational conditions.

The Michelin X STRADDLE 2 CC is only available in certain regions of the world and for specific uses.

LEARN MORE

ON THE WEB
business.michelin.co.uk

TESTIMONIALS
youtube.com/michelinearthmover

TOOLS

BEYOND ROAD SELECTOR
beyond-road.selector.michelingroup.com/mh

CONTACT

Please contact your local sales representative for more information.

MICHELIN X STRADDLE 2

TECHNICAL CHARACTERISTICS

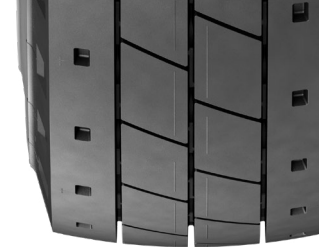

DESCRIPTION	CAI [MSPN]	Max.dist./ hour km [mile]	Section width mm [in]	Outer diameter mm [in]	Static load radius mm [in]	Rolling circumference mm [in]	Tread depth mm [32nd]	Dual spacing mm [in]	Capacity liter [gal]	Measuring recommended rim	Other approved rims mm [in]
450/95R25 X STRADDLE 2 204A5 TL	272326 38706	15 9.3	422 16.6	1510 59.4	670 26.4	4530 178.3	50 63	- -	342 90.4	11.25/2.0	13.00/2.0

LOAD CAPACITY BASED ON INFLATION PRESSURE AND SPEED

Bar Psi 6 87 8 116 10 145

Machine - use kg - lbs		EXCLUSIVE STRADDLE CARRIER USAGE CONDITIONS*									
22 km/h	14 mph	11025	24310			13600	29988			16800	37044
25 km/h	15 mph	10500	23153			12950	28555			16000	35280
35 km/h	22 mph	9700	21389			11950	26350			14800	32634

MOUNTING ACCESSORIES	Recommended rim	Tubeless bead seal [CAI]	Rubber seal [CAI]	Tube [CAI]	Flap [CAI]
	11.25/2.0	-	OR 3-25 SULLA [553200]	-	-

DESCRIPTION	CAI [MSPN]	Max.dist./ hour km [mile]	Section width mm [in]	Outer diameter mm [in]	Static load radius mm [in]	Rolling circumference mm [in]	Tread depth mm [32nd]	Dual spacing mm [in]	Capacity liter [gal]	Measuring recommended rim	Other approved rims mm [in]
450/95R25 X STRADDLE 2 CC 204A5	988724 -	17 10.5	422 16.6	1510 59.4	670 26.4	4530 178.3	50 63	- -	342 90.4	11.25/2.0	13.00/2.0

LOAD CAPACITY BASED ON INFLATION PRESSURE AND SPEED

Bar Psi 6 87 8 116 10 145

Machine - use kg - lbs		EXCLUSIVE STRADDLE CARRIER USAGE CONDITIONS*									
22 km/h	14 mph	11025	24310			13600	29988			16800	37044
25 km/h	15 mph	10500	23153			12950	28555			16000	35280
35 km/h	22 mph	9700	21389			11950	26350			14800	32634

MOUNTING ACCESSORIES	Recommended rim	Tubeless bead seal [CAI]	Rubber seal [CAI]	Tube [CAI]	Flap [CAI]
	11.25/2.0	-	OR 3-25 SULLA [553200]	-	-

DESCRIPTION	CAI [MSPN]	Max.dist./ hour km [mile]	Section width mm [in]	Outer diameter mm [in]	Static load radius mm [in]	Rolling circumference mm [in]	Tread depth mm [32nd]	Dual spacing mm [in]	Capacity liter [gal]	Measuring recommended rim	Other approved rims mm [in]
480/95R25 X STRADDLE 2 208A5 TL	951824 07011	15 9.3	467 18.4	1553 61.1	687 27	4655 183.3	50 63	580 22.8	410 108.3	13.00/2.5	11.25/2.0 [1.7]

LOAD CAPACITY BASED ON INFLATION PRESSURE AND SPEED

Bar Psi 6 87 8 116 10 145

Machine - use kg - lbs		EXCLUSIVE STRADDLE CARRIER USAGE CONDITIONS*									
22 km/h	14 mph	12450	27452			15800	34839			18900	41675
25 km/h	15 mph	11900	26240			15050	33185			18000	39690
35 km/h	22 mph	11000	24255			13900	30650			16650	36713

MOUNTING ACCESSORIES	Recommended rim	Tubeless bead seal [CAI]	Rubber seal [CAI]	Tube [CAI]	Flap [CAI]
	13.00/2.5	-	OR 3-25 SULLA [553200]	-	-

IMPORTANT

The inflation pressure must always be appropriate for the load per tire, the speed of travel and the work to be done. Our recommendations above are provided subject to changes made after the date of publication of these tables (October 2020). Technical data is subject to change without prior notice.

* Michelin X STRADDLE 2 tire models are designed for straddle carrier use unless otherwise specified by Michelin's Technical and Quality departments.

MICHELIN X STRADDLE 2

TECHNICAL CHARACTERISTICS

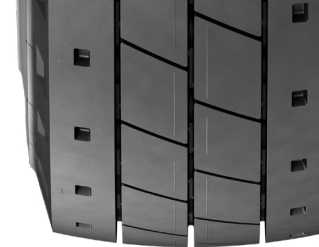

DESCRIPTION	CAI [MSPN]	Max.dist./ hour km [mile]	Section width mm [in]	Outer diameter mm [in]	Static load radius mm [in]	Rolling circumference mm [in]	Tread depth mm [32nd]	Dual spacing mm [in]	Capacity liter [gal]	Measuring recommended rim	Other approved rims mm [in] <small>See end of document for more options</small>
480/95R25 X STRADDLE 2 CC 208A5 TL	324916 07011	17 10.5	467 18.4	1553 61.1	687 27	4655 183.3	50 63	580 22.8	410 108.3	13.00/2.5	11.25/2.0 [1.7]

LOAD CAPACITY BASED ON INFLATION PRESSURE AND SPEED

Bar	Psi	6		8		10		
		87		116		145		
Machine - use kg - lbs		EXCLUSIVE STRADDLE CARRIER USAGE CONDITIONS*						
22 km/h	14 mph	12450	27452	15800	34839	18900	41675	
25 km/h	15 mph	11900	26240	15050	33185	18000	39690	
35 km/h	22 mph	11000	24255	13900	30650	16650	36713	
MOUNTING ACCESSORIES	Recommended rim	Tubeless bead seal [CAI]		Rubber seal [CAI]		Tube [CAI]		Flap [CAI]
	13.00/2.5	-		OR 3-25 SULLA [553200]		-		-

IMPORTANT

The inflation pressure must always be appropriate for the load per tire, the speed of travel and the work to be done. Our recommendations above are provided subject to changes made after the date of publication of these tables (October 2020). Technical data is subject to change without prior notice.

* Michelin X STRADDLE 2 tire models are designed for straddle carrier use unless otherwise specified by Michelin's Technical and Quality departments.

MICHELIN X TERMINAL T



1 VERSATILITY

Simplify your operations
Equip all terminal tractors and trailers with the same size and tread.

2 PRODUCTIVITY

Minimize downtime
Tubeless tire with steel radial structure. This construction provides high puncture resistance.

3 SAFETY

High level of grip for an excellent performance on wet ground
Radial structure with optimized tread pattern for enhanced ground contact (additional antistatic properties).

TIRE CHARACTERISTICS



ADDITIONAL INFORMATION

VEHICLE EQUIPMENT



The X TERMINAL T is the leading solution in combining exceptional puncture resistance with outstanding long life.

- Michelin Industrial and Port
Tires Product Manager

LEARN MORE

ON THE WEB
business.michelin.co.uk

TESTIMONIALS
youtube.com/michelinearthmover

TOOLS

BEYOND ROAD SELECTOR
beyond-road.selector.michelingroup.com/mh

CONTACT

Please contact your local sales representative for more information.

MICHELIN X TERMINAL T

TECHNICAL CHARACTERISTICS



DESCRIPTION	CAI [MSPN]	Max.dist./ hour km [mile]	Section width mm [in]	Outer diameter mm [in]	Static load radius mm [in]	Rolling circumference mm [in]	Tread depth mm [32nd]	Dual spacing mm [in]	Capacity liter [gal]	Measuring recommended rim	Other approved rims mm [in] <small>See end of document for more options</small>
280/75R22.5 168A8 TL	004371 33193	20 12.4	279 11	995 39.2	447 17.6	3000 118.1	31 39.1	326 12.8	85 22.5	8.25	-

LOAD CAPACITY BASED ON INFLATION PRESSURE AND SPEED

Bar	Psi					8	116				10	145	
Machine - use kg - lbs		TERMINAL TRACTOR											
STATIC		5350	11797			6900	15215			8450	18632		
5 km/h	3 mph	5060	11157			6450	14222			7840	17287		
10 km/h	6 mph	4370	9636			5800	12789			7280	16052		
25 km/h	15 mph	4200	9261			5300	11687			6300	13892		
40 km/h	25 mph	3750	8269			4675	10308			5600	12348		

MOUNTING ACCESSORIES	Recommended rim	Tubeless bead seal [CAI]	Rubber seal [CAI]	Tube [CAI]	Flap [CAI]
	8.25	N/A	N/A	N/A	N/A

310/80R22.5 175A8 TL	278144 03379	20 12.4	307 12.1	1084 42.7	483 19	3257 128.2	30 37.8	355 14	116 30.6	9.0	-
-----------------------------	-----------------	------------	-------------	--------------	-----------	---------------	------------	-----------	-------------	-----	---

LOAD CAPACITY BASED ON INFLATION PRESSURE AND SPEED

Bar	Psi					8	116				10	145	
Machine - use kg - lbs		TERMINAL TRACTOR											
STATIC		6890	15192			8655	19084			10420	22976		
5 km/h	3 mph	6160	13583			7910	17442			9660	21300		
10 km/h	6 mph	5930	13076			7450	16427			8970	19779		
25 km/h	15 mph	5080	11201			6420	14156			7760	17111		
40 km/h	25 mph	4450	9812			5675	12513			6900	15215		

MOUNTING ACCESSORIES	Recommended rim	Tubeless bead seal [CAI]	Rubber seal [CAI]	Tube [CAI]	Flap [CAI]
	9.0	N/A	N/A	N/A	N/A

310/80R22.5 175A8 TL MEC PHASED OUT	508353 03379	20 12.4	307 12.1	1084 42.7	483 19	3257 128.2	30 37.8	355 14	116 30.6	9.0	-
--	-----------------	------------	-------------	--------------	-----------	---------------	------------	-----------	-------------	-----	---

LOAD CAPACITY BASED ON INFLATION PRESSURE AND SPEED

Bar	Psi					8	116				10	145	
Machine - use kg - lbs		TERMINAL TRACTOR (INTENSE USE)											
STATIC		6890	15192			8655	19084			10420	22976		
5 km/h	3 mph	6160	13583			7910	17442			9660	21300		
10 km/h	6 mph	5930	13076			7450	16427			8970	19779		
25 km/h	15 mph	5080	11201			6420	14156			7760	17111		
40 km/h	25 mph	4450	9812			5675	12513			6900	15215		

MOUNTING ACCESSORIES	Recommended rim	Tubeless bead seal [CAI]	Rubber seal [CAI]	Tube [CAI]	Flap [CAI]
	9.0	N/A	N/A	N/A	N/A

MICHELIN X[®] TERMINAL T HD



1 ROBUSTNESS

High endurance in demanding conditions

Heavy-duty tire structure with a better bead package⁽¹⁾ and reinforced crown belt⁽²⁾, utilizing high tensile cords to enhance performance life until complete wear.

2 CASING DURABILITY

Extended wear life

IND4 tread depth to better tire life and minimize puncture risks. Extra tread underlay rubber helps protect the crown against corrosion and stone retention.

This tire can be regrooved.

3 SAFETY

Enhanced air tightness

Thicker inner liner⁽³⁾ to prevent corrosion and ensure long service life.

TIRE CHARACTERISTICS

ADDITIONAL INFORMATION



VEHICLE EQUIPMENT



The X[®] TERMINAL T HD is designed for a long life under severe conditions thanks to its reinforced structure.

Choosing this tire means optimizing your investment.

- Michelin Industrial and Port Tires Product Manager

This product is intended for very specific use in certain regions of the world. Please consult your representative for more information.

⁽¹⁾The bead endurance reinforcement is enhanced by 70%, compared to the X[®] TERMINAL T model, in the same dimension. The tests were conducted in January 2025, in France, at Michelin's request. The results may vary.

⁽²⁾The crown reinforcement is increased by 40% compared to the X[®] TERMINAL T model, in the same dimension. The tests were conducted in November 2024 and in two phases, in France and in Spain, at Michelin's request. The results may vary.

⁽³⁾The inner liner thickness is increased by 50% compared to the MICHELIN X[®] TERMINAL T model, based on evaluations using Michelin R&D's dedicated simulation software.

LEARN MORE

ON THE WEB
business.michelin.co.uk

TESTIMONIALS
youtube.com/michelinearthmover

TOOLS

BEYOND ROAD SELECTOR
beyond-road.selector.michelingroup.com/mh

CONTACT

Please contact your local sales representative for more information.

MICHELIN X TERMINAL T HD



TECHNICAL CHARACTERISTICS

DESCRIPTION	CAI [MSPN]	Max.dist./ hour km [mile]	Section width mm [in]	Outer diameter mm [in]	Static load radius mm [in]	Rolling circumference mm [in]	Tread depth mm [32nd]	Dual spacing mm [in]	Capacity liter [gal]	Measuring recommended rim	Other approved rims mm [in]
310/80R22.5 175A8 TL HD	494623 99605	20 12.4	296 11.7	1084 42.7	484 19.1	3257 128.2	27 34	355 14	115 4.1	9.0	8.25

LOAD CAPACITY BASED ON INFLATION PRESSURE AND SPEED

Bar		Psi		6		8		10			
				87		116		145			
Machine - use kg - lbs		TERMINAL TRACTOR (INTENSIVE USE)									
STATIC		6890	15192			8655	19084			10420	22976
5 km/h	3 mph	6160	13583			7910	17442			9660	21300
10 km/h	6 mph	5930	13076			7450	16427			8970	19779
25 km/h	15 mph	5080	11201			6420	14156			7760	17111
40 km/h	25 mph	4450	9812			5675	12513			6900	15215

MOUNTING ACCESSORIES	Recommended rim	Tubeless bead seal [CAI]	Rubber seal [CAI]	Tube [CAI]	Flap [CAI]
	9.0	N/A	N/A	N/A	N/A



1 ROBUSTNESS

Optimize machine uptime
New generation of radial tire, developed to ensure maximal reliability on automated machines.

2 TREADLIFE

Improve service life ⁽¹⁾
Smooth pattern designed with specific rubber compound for an optimized tire life.

3 ENERGY EFFICIENCY

Get up to 40% reduction in rolling resistance ⁽²⁾
Specifically designed radial structure with low resistance overall rubber compounds.

TIRE CHARACTERISTICS

ADDITIONAL INFORMATION



VEHICLE EQUIPMENT



Energy efficiency and productivity are key points for port operation competitiveness. Advanced automated systems and electrification of ports are answering this demand. This calls for tires capable of smooth and continuous operations with the lowest energy consumption possible and an outstanding wear life. Our new X AGV^{EV} tires fully support these challenges.

- Michelin Industrial and Port
Tires Product Manager

⁽¹⁾ Expect to be in operations over 20,000 hours / 4 years under standard operation. Tire tested in real conditions, port of Rotterdam, from 2020 to 2021.

⁽²⁾ Compared to premium BIAS and Radial tires on AGV market. Rolling resistance measured in Michelin Center, in Ladoux, from 2020 to 2021.

LEARN MORE

ON THE WEB
business.michelin.co.uk

TESTIMONIALS
youtube.com/michelinearthmover

TOOLS

BEYOND ROAD SELECTOR
beyond-road.selector.michelingroup.com/mh

CONTACT

Please contact your local sales representative for more information.

TECHNICAL CHARACTERISTICS

DESCRIPTION	CAI [MSPN]	Max.dist./ hour km [mile]	Section width mm [in]	Outer diameter mm [in]	Static load radius mm [in]	Rolling circumference mm [in]	Tread depth mm [32nd]	Dual spacing mm [in]	Capacity liter [gal]	Measuring recommended rim	Other approved rims mm [in] <small>See end of document for more options</small>
18.00R25 207A5	677019 26910	14 8.7	506 19.9	1656 65.2	750 29	5006 197	40 50	612 24.1	534 141.2	13.00/2.5	15.00/2.5

LOAD CAPACITY BASED ON INFLATION PRESSURE AND SPEED

Bar Psi 6 87 8 116 10 145

Machine - use
kg - lbs

CONTAINER TRANSPORTER PLATFORMS (AGV) - RATED LOAD

STATIC	18380	40528	22280	49127	26250	57881
10 km/h <i>6 mph</i>	15930	35126	19180	42292	22750	50164
25 km/h <i>15 mph</i>	12250	27011	14750	32524	17500	38588

Machine - use
kg - lbs

CONTAINER TRANSPORTER PLATFORM (AGV) - MAX CYCLIC LOAD

10 km/h <i>6 mph</i>	18380	40528	22280	49127	26250	57881
25 km/h <i>15 mph</i>	15930	35126	19180	42292	22750	50164

MOUNTING ACCESSORIES	Recommended rim	Tubeless bead seal [CAI]	Rubber seal [CAI]	Tube [CAI]	Flap [CAI]
	13.00/2.5	N/A	OR 3-25 SULLA [553200]	25WAM [944085]	16-24/25

21.00R25 213A5

043270 24573	14 8.7	559 22	1744 68.7	750 29	5006 197	40 50	742 29.2	686 181.2	15.00/3.0	-
-----------------	-----------	-----------	--------------	-----------	-------------	----------	-------------	--------------	-----------	---

LOAD CAPACITY BASED ON INFLATION PRESSURE AND SPEED

Bar Psi 6 87 8 116 10 145

Machine - use
kg - lbs

CONTAINER TRANSPORTER PLATFORMS (AGV) - RATED LOAD

STATIC	21000	46305	24800	54684	30900	68135
10 km/h <i>6 mph</i>	19000	41895	22000	48510	26780	59050
25 km/h <i>15 mph</i>	14000	30870	17400	38367	20600	45423

Machine - use
kg - lbs

CONTAINER TRANSPORTER PLATFORM (AGV) - MAX CYCLIC LOAD

10 km/h <i>6 mph</i>	19000	41895	22000	48510	26780	59050
25 km/h <i>15 mph</i>	19000	41895	22000	48510	26780	59050

MOUNTING ACCESSORIES	Recommended rim	Tubeless bead seal [CAI]	Rubber seal [CAI]	Tube [CAI]	Flap [CAI]
	15.00/3.0	N/A	OR 3-25 SULLA [553200]	N/A	N/A



SPECIFIC APPLICATIONS

Please note that tires for mechanical handling equipment used in areas where there is a high risk of fire or explosion, such as the chemical and petrochemical industries, must meet certain standards concerning their electrical resistivity. When the electrical resistance measured according to ISO 16392 or WDK 110 standards is lower than 10^6 Ohms, then the tire is able to dissipate static charges from the vehicle, and its sidewall features the following symbol.



PERFORMANCE

Any and all tire performance claims or comparisons contained herein are for informational purposes only to aid in the selection of a tire and **do not** constitute any form of performance guarantee or warranty. Individual results may vary. Such information may not be used as a basis for any performance guarantee or warranty claim.

MICHELIN TECHNICAL DATA

INDUSTRIAL PNEUMATIC TIRES
RADIAL TECHNOLOGY

TECHNICAL INFORMATION

TIRE CONSTRUCTION

DIAGONAL OR BIAS TIRES CONSTRUCTION	PAGE 45
RADIAL TIRES CONSTRUCTION	PAGE 46
SOLID TIRES CONSTRUCTION	PAGE 47

GENERAL INFORMATION

DIFFERENT TIRE SERIES	PAGE 48
DIFFERENT TIRE SIZE DESIGNATIONS	PAGE 48
TIRE MARKING	PAGE 49
LOAD INDEX AND SPEED SYMBOL	PAGE 50
READING GUIDE FOR PRESSURE, LOAD AND USAGE TABLES	PAGE 50

LOAD CAPACITY FUNCTION OF SPEED FOR VARIOUS APPLICATIONS

CYCLIC SERVICE	PAGE 51
----------------	---------

ADVICE AND RECOMMENDATIONS ON THE USE OF MANUFACTURING TIRES

NITROGEN INFLATION	PAGE 52
INSERTS AND SOLID FILLS	PAGE 53

OTHER RADIAL TIRES USED FOR MECHANICAL HANDLING

CONDITION OF USE	PAGE 53
------------------	---------

TUBELESS BEAD SEAL

MICHELIN TUBELESS BEAD SEAL 8" TO 20" RIMS	PAGE 54
SIZE MARKING	PAGE 55
APPROVED RIMS	PAGE 56
APPROVED RIMS FOR MANUFACTURING	PAGE 57
FLAP + TUBE SOLUTION	PAGE 58
CORNER SEAL AND O-RING SOLUTION	PAGE 59
VALVES AND ASSOCIATED ACCESSORIES	PAGE 60
TRUCK-TYPE VALVE	PAGE 61
TYPES OF TUBELESS EARTHMOVER VALVES	PAGE 62
EARTHMOVER TUBELESS VALVE	PAGE 63

APPROXIMATE LOOSE MATERIAL DENSITIES

UNITS OF MEASURE AND CONVERSION TABLES	PAGE 64
--	---------

TIRE CONSTRUCTION

DIAGONAL OR BIAS TIRES CONSTRUCTION

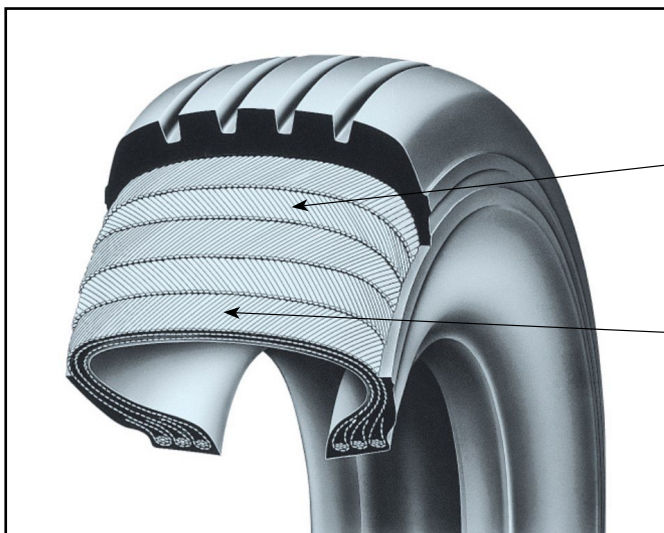

Crown and sidewalls functions are not differentiated

The casing is made of several textile plies positioned in a crisscross manner

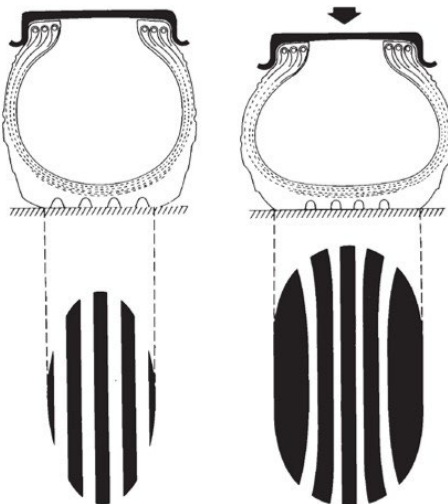

GOOD TO KNOW

Important heat buildup



Reduced productivity
(Low transport distance)

Parasite frictions with the ground
High distortion of the tire footprint



Low wear performance

TIRE CONSTRUCTION

RADIAL TIRES CONSTRUCTION



The crown belt is made of several working and protecting steel plies.

The casing is made of steel with a double protection at the sidewall.

**CROWN AND
SIDEWALLS
ARE WORKING
SEPARATELY**

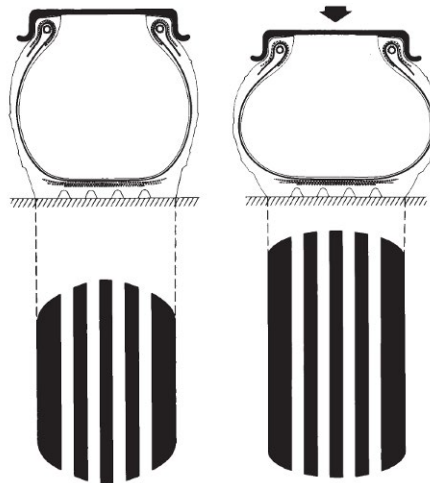

GOOD TO KNOW

Low heat buildup



Extended productivity
(Long transport distance)

Even frictions with the ground



Low distortion of the footprint



Improved wear performance

TIRE CONSTRUCTION

SOLID TIRES CONSTRUCTION

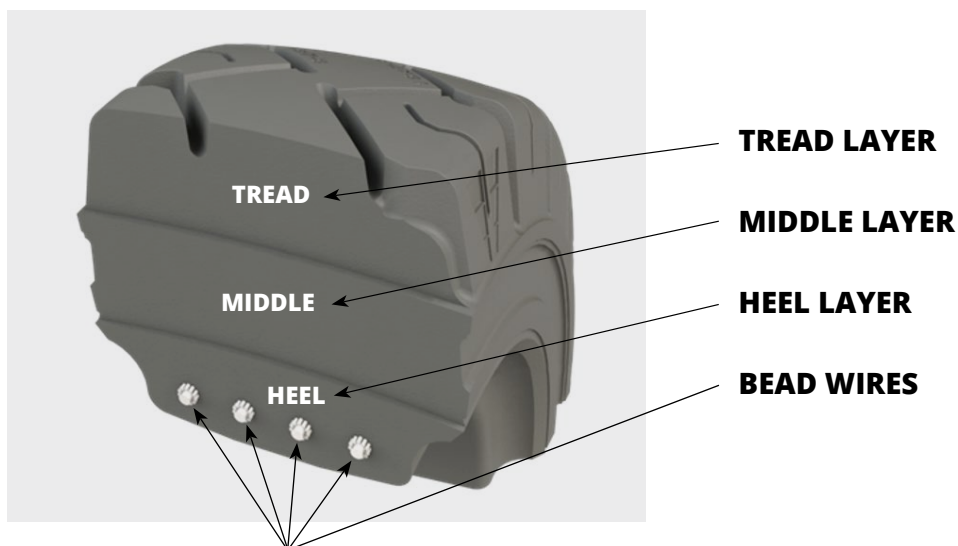

2 DIFFERENT TIRE FITMENTS / MODELS:

STANDARD HEEL

Need all rim component to be fitted.
(Flange, lockring, bead seat band)



QUICK HEEL

The tire profile self locks in the rim hub.
No need of further rim components.

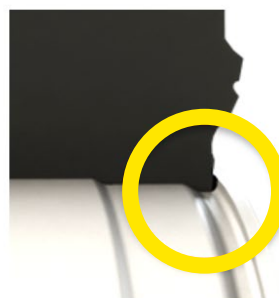

GOOD TO KNOW

High heat buildup



Minimal intensity
(Limited transport distance)

Reduced tire footprint



Minimal wear performance (h/mm)

No inflation pressure



Low-maintenance product

GENERAL INFORMATION

THE DIFFERENT TIRE SERIES

There are different tire series categorized by the aspect ratio **H/S**:
(the ratio in % between the sidewall height and the tire width).

H = standard section height **S** = standard section width

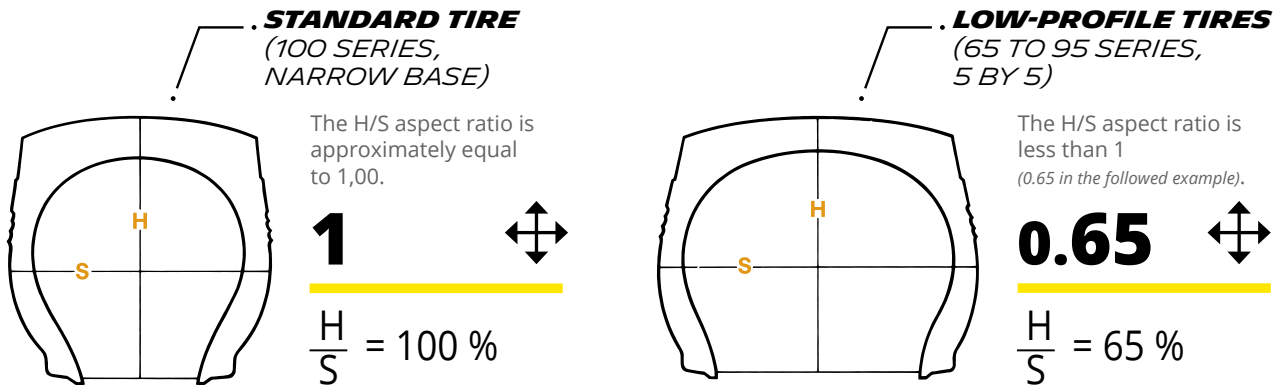

The section width, given in inches, is a whole number
e.g.: 12.00 R 20
or the section width, given in inches, is a whole number followed by a fraction.
e.g.: 8.25 R 15

The aspect ratio is not indicated in the size designation.

The nominal section width is expressed as a measurement in millimeters followed by the aspect ratio 65 to 95 (65 in the example).
e.g.: 355/65 R 15

THE DIFFERENT TIRE SIZE DESIGNATIONS

RIM DIAMETER	TIRE TECHNOLOGY / SIZE EQUIVALENT MARKINGS			SIZE DETAILS						
	SOLID	BIAS	RADIAL	OD	SW		ASPECT RATIO	RIM DIAMETER	LI	SI
				(in)	(in)	(mm)	(H/S)	(in)	(ETRTO)	(ETRTO)
4	4.80 - 4	4.00 - 4			4			4		
8	4.80 - 8	4.00 - 8			4			8		
	5.70 - 8	5.00 - 8	5.00 R 8		5			8	111	A5
	15 x 4.5 - 8	125/75 - 8		15	4.5	125	75	8		
	16 x 6 - 8	150/75 - 8	150/75 R 8	16	6	150	75	8	113	A5
9	18 x 7 - 8	180/70 - 8	180/70 R 8	18	7	180	70	8	125	A5
	6.90 - 9	6.00 - 9 (6.90 - 9)	6.00 R 9		6			9	134	A5
	21 x 8 - 9	200/75 - 9	200/75 R 9	21	8	200	75	9	121	A5
10		6.50 - 10	6.50 R 10		6.5			10	128	A5
	23 x 9 - 10	225/75 - 10	225/75 R 10	23	9	225	75	10	142	A5
12		7.00 - 12	7.00 R 12		7			12	136	A5
	23 x 10 - 12	250/60 - 12	250/60 R 12	23	10	250	60	12		
	27 x 10 - 12	250/75 - 12	250/75 R 12	27	10	250	75	12	152	A5
15		7.00 - 15	7.00 R 15		7			15	143	A5
		7.50 - 15	7.50 R 15		7.5			15	146	A5
	28 x 9 - 15	225/75 - 15 (8.15 - 15)	225/75 R 15	28	9	225	75	15	149	A5
		8.25 - 15	8.25 R 15		8.25			15	153	A5
		250/70 - 15 (250 - 15)	250/70 R 15		10	250	70	15	153	A5
		315/70 - 15 (300 - 15)	315/70 R 15		10	315	70	15	165	A5
	28 x 12.5 - 15	355/45 - 15		28	12.5	355	45	15		
32 x 12.1 - 15		355/65 R 15	32	12.1	355	65	15	175	A5	

OD: Outer Diameter S/SW: Section Width H/HS: Section High LI: Load Index SI: Speed Index PR: Ply Rating

TIRE MARKING



For special conditions usage, please consult us.

MICHELIN®	Manufacturer
15	Nominal section width in inches
75	Tire aspect ratio (H/S = 0,65)
R	Radial construction
STABIL'X	Old name of the family being deleted
XZM	XZM range name
170	Load Index
A5	Speed Symbol: 25 km/h
CYCLIC	Cyclic use (see explanation on following pages)
RADIAL X	Indication of tire structure
	Electrical resistance is lower than 10 ⁶ Ohms

FOR MORE DETAILS CONCERNING:

Choice of tire, use of tire, fitting, operation pressure and storage and maintenance, consult **USE AND MAINTENANCE GUIDE FOR MICHELIN EARTHMOVER TIRES.**



LOAD INDEX AND SPEED SYMBOL

Industrial and handling tires bear a Load Index and a Speed Symbol. The **LOAD INDEX** is a numerical code from international standard tires, which indicates the reference load capacity.

LOAD INDEX	LOAD IN KG	LOAD INDEX	LOAD IN KG	LOAD INDEX	LOAD IN KG	LOAD INDEX	LOAD IN KG	LOAD INDEX	LOAD IN KG	LOAD INDEX	LOAD IN KG
100	800	120	1400	140	2500	160	4500	180	8000	200	14000
101	825	121	1450	141	2575	161	4625	181	8250	201	14500
102	850	122	1500	142	2650	162	4750	182	8500	202	15000
103	875	123	1550	143	2725	163	4875	183	8750	203	15500
104	900	124	1600	144	2800	164	5000	184	9000	204	16000
105	925	125	1650	145	2900	165	5150	185	9250	205	16500
106	950	126	1700	146	3000	166	5300	186	9500	206	17000
107	975	127	1750	147	3075	167	5450	187	9750	207	17500
108	1000	128	1800	148	3150	168	5600	188	10000	208	18000
109	1030	129	1850	149	3250	169	5800	189	10300	209	18500
110	1060	130	1900	150	3350	170	6000	190	10600	210	19000
111	1090	131	1950	151	3450	171	6150	191	10900	211	19500
112	1120	132	2000	152	3550	172	6300	192	11200	212	20000
113	1150	133	2060	153	3650	173	6500	193	11500	213	20600
114	1180	134	2120	154	3750	174	6700	194	11800	214	21200
115	1215	135	2180	155	3875	175	6900	195	12150	215	21800
116	1250	136	2240	156	4000	176	7100	196	12500	216	22400
117	1285	137	2300	157	4125	177	7300	197	12850	217	23000
118	1320	138	2360	158	4250	178	7500	198	13200	218	23600
119	1360	139	2430	159	4375	179	7750	199	13600	219	24300

The reference load corresponds to the load index of the designation.

The **SPEED SYMBOL** is a numerical code from international standard tires, which indicates the maximum speed at which the tire can carry a load corresponding to its load index, under specified conditions.

SPEED SYMBOL	A1	A2	A3	A4	A5	A6	A7	A8	B	C	D	E	F	G	J	K	L
Speed (km/h)	5	10	15	20	25	30	35	40	50	60	65	70	80	90	100	110	120

READING GUIDE FOR PRESSURE, LOAD AND USAGE TABLES

The shaded box of load/pressure tables is the value defined by the industry standards.

Up to this limit, the tire works in an optimal zone leading to a better balance of performance.

The use of MICHELIN® tires outside the specification of load/pressure/use tables must be validated by your Michelin Representative.

The MICHELIN® Radial tires used in Mechanical Handling and presented in this document are designed for a cyclic service. This is defined as **mechanical handling, cyclic service**.

LOAD CAPACITY FUNCTION OF SPEED

FOR VARIOUS APPLICATIONS*

CYCLIC SERVICE

CYCLIC SERVICE covers usages where tires are not used continuously at their rated speed and load. Vehicle usually operate one way loaded and one way empty (e.g. Forklifts, Terminal Tractors, Straddle Carriers, ...).

All axles of the vehicle may not be submitted to the same load, and this is the reason why an extra 30% load capacity can be authorized on the front axles (load wheels) of counter balanced forklift trucks when the rear axles (steering wheels) holding the counterweight permanently will be limited to the 105% its rated load only.

The following graphic describes those of the main usage in material handling.

Counter Balanced Forklift truck prevail for all counter-balanced vehicle (e.g. Empty Container Handler, Top Lift Full Container Handler, Reach Stacker, ...)

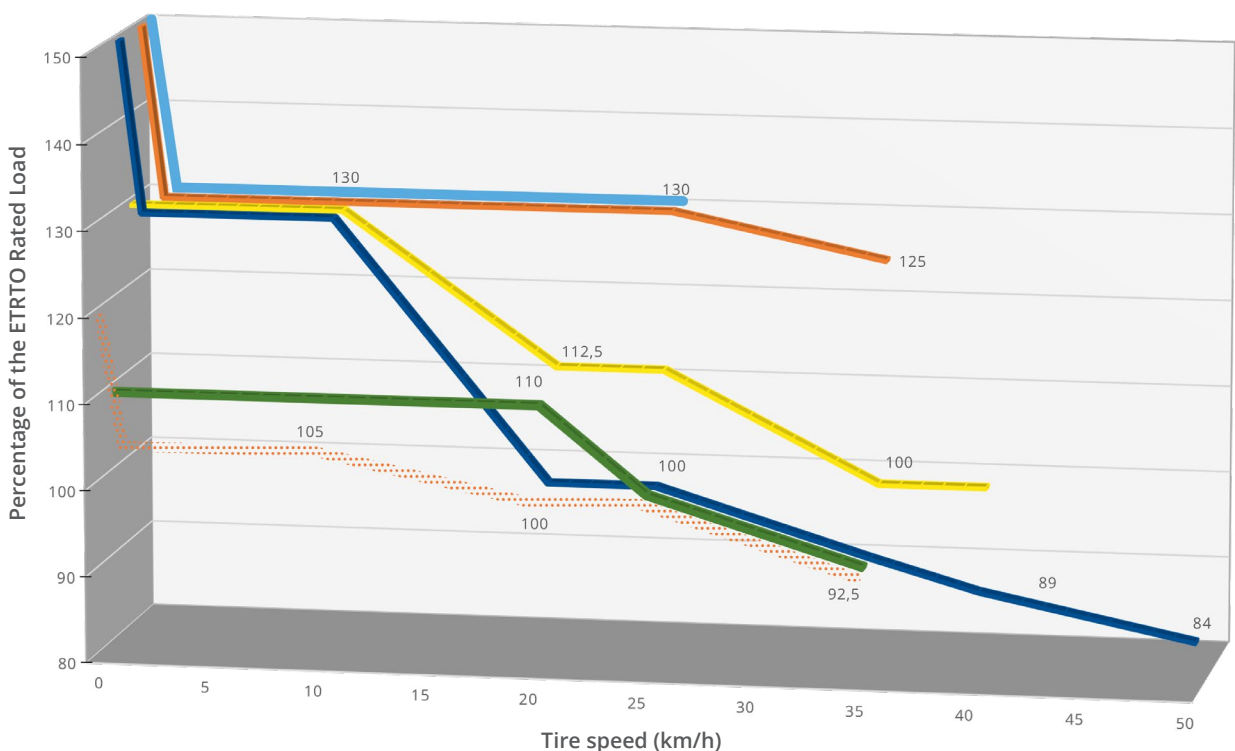

Load wheels **Steer wheels**
Counter balanced forklift truck



Straddle carrier



Terminal tractor and trailer



AGV



Towbarless aircraft tractor load wheels
Slag pot carrier load wheels

In case where the maximal load, speed, distance in an hour may be exceeded with specific machine/usages, please contact your Michelin representative to apply for a specific usage authorization request.

* ETRTO 2023 reference

ADVICE AND RECOMMENDATIONS

ON THE USE OF INDUSTRIAL TIRES

NITROGEN INFLATION

INTRODUCTION

Under most circumstances, the air inflation is suitable for our tires and allows them to work in the best conditions.

WHEN SHOULD NITROGEN INFLATION BE RECOMMENDED ?

Nitrogen, an inert and stable gas with a larger molecule, diffuses more slowly than oxygen through rubber, limiting the risk of oxidation of different parts of the tire (rubber, cables, etc.). It also slows the loss of inflation pressure.

For obvious safety reasons, this type of inflation is always advisable in the following conditions:

- atmospheres where there is a risk of explosion;
- contact with (or proximity to) molten materials (foundries, steel works, glass works, etc.);
- where there is a risk of electric arcs (near high voltage lines or cables, lightning, etc.);
- working conditions that may lead to a significant rise in tire temperature due to transmission of heat from the engine, hubs, brakes, etc.

Nitrogen inflation is a well-adapted solution for use with mechanical handling equipment.

EQUIPMENT NECESSARY

To install an effective inflation system, Michelin recommends:

- 2 gas bottles of compressed nitrogen
- 1 nitrogen regulator
- An inflation tool in compliance with local regulations.

CAUTION:

Nitrogen inflation equipment should only be used by properly trained individuals. A properly functioning regulator must always be used and all manufacturer's instructions followed. Failure to do so can lead to personal injury.

SUPPLIERS: Contact your local specialist in compressed gases.

VOLUME OF NITROGEN NECESSARY TO INFLATE A TIRE

The quantity of nitrogen necessary to inflate a tire is proportional to its internal volume and the inflation pressure required.

The volumes of the industrial tires are shown in the following tables (characteristics of MICHELIN® Industrial Tires).

Example: 250 / 70 R 15 XZM TL

Interior volume is 39 liters.

For a pressure of 10 bars, the quantity of nitrogen needed is: $39 \times 10 = 390$ liters.

OTHER RADIAL TIRES

USED FOR MECHANICAL HANDLING

INSERTS AND SOLID FILLS

Inserts and solid fills are sometimes used in lieu of air or nitrogen. This technique is adapted for specific uses only.

Their implementation requires qualified personnel.

The preceding information is extracted from the **USE AND MAINTENANCE GUIDE FOR MICHELIN® EARTHMOVER TIRES.**

For more details, consult our [website](#) OR YOUR MICHELIN REPRESENTATIVE.



CONDITION OF USE

The range of MICHELIN® industrial tires has been specifically designed to equip industrial machines. The sizes are specific to these machines and their work; the loads and speeds correspond to standardized figures.

Each time tires need to be fitted to mechanical handling equipment, the following rules should be followed:

- 1°) When the tire size exists in the industrial tire range, the industrial tire must be used.
- 2°) When size does not exist in the industrial tire range, it may be necessary to consult other tire ranges (Agriculture, Truck or Earthmover), whose characteristics are compatible.

In all cases, contact your Michelin Representative who will be able to guide you on the best solution. Technical validation will be provided by Michelin Representative for these uses.

TUBELESS BEAD SEAL

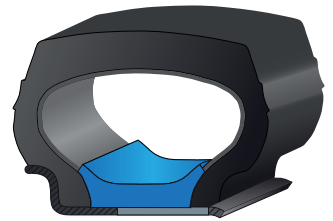

MICHELIN TUBELESS BEAD SEAL 8" TO 20" RIMS

RIM & TIRE SIZES					TBS (TUBELESS BEAD SEAL)			
RIM DIAM. (INCH)	RIM WIDTH (INCH)	TIRE SIZE	RANGE	TIRE CAI	DESCRIPTION	VALVE TYPE	PLASTIC PLUG	TBS SET CAI
8	3.25I	5.00 R 8	XZM	110208	80 TL 8	R 2160	-	102150
	3.00D	5.00 R 8	XZM	110208	80 TL 8	R 2160	-	102150
	4.33R	150/75 R 8	XZM	110087	110 TL 8	R 2102	-	613972
	4.33R	180/80R8	XZM	110069	110 TL 8	R 2102	-	613972
9	4.00E	6.00R9	XZM, XZR	110204	100 TL 9	R 2160	-	102151
	6.00E	200/75R9	XZM	110090	150 TL 9	R 2102	R 2110	102182
10	5.00F	6.50R10	XZM, XZR	110213	125 TL 10	R 2102	-	102183
	6.50F	225/75R10	XZM	110089	165 TL 10	R 2102	R 2110	102184
12	5.00S	7.00R12	XZM, XZR	110195	125 TL 12	R 2161	-	522788
	8.00G	250/60R12	XZM	358151	200 TL 12	R 2102	R 2110	787198
	8.00G	250/75R12	XZM	110108	200 TL 12	R 2102	R 2110	787198
15	5.5	7.00R15	XZM	110211	140 TL 15	R 2102	-	454346
	6.0	7.00R15	XZM	110211	150 TL 15	R 2102	R 2110	702507
	6.0	7.50R15	XZM	110214	150 TL 15	R 2102	R 2110	702507
	6.5	7.50R15	XZM	110214	165 TL 15	R 2102	R 2110	575769
	6.5	8.25R15	XZM	110218	165 TL 15	R 2102	R 2110	575769
	7.0	8.25R15	XZM	110218	175 TL 15	R 2102	R 2110	260511
	7.0	225/75R15	XZM	110079	175 TL 15	R 2102	R 2110	260511
	7.0	250/70R15	XZM	110075	175 TL 15	R 2102	R 2110	260511
	7.5	250/70R15	XZM	110075	190 TL 15	R 2102	R 2110	464164
	8.0	315/70R15	XZM	110109	200 TL 15	R 2102	R 2110	609679
9.75	355/65R15	XZM	003789	250 TL 15	R 2102	R 2110	26320	
20	7.0	9.00R20	XZM	110185	175 TL 20	R 2102	R 2110	102087
	7.5	9.00R20	XZM	110185	190 TL 20	R 2102	R 2110	102083
	7.0	10.00R20	XZM	110014	175 TL 20	R 2102	R 2110	102087
	7.5	10.00R20	XZM	110014	190 TL 20	R 2102	R 2110	102083
	8.0	10.00R20	XZM	110014	200 TL 20	R 2102	R 2110	102085
	7.5	11.00R20	XZM	110189	190 TL 20	R 2102	R 2110	102083
	8.0	11.00R20	XZM	110189	200 TL 20	R 2102	R 2110	102085
	8.5	11.00R20	XZM	110189	215 TL 20	R 2102	R 2110	102086
	8.0	12.00R20	XZM	110082	200 TL 20	R 2102	R 2110	102085
	8.5	12.00R20	XZM	110082	215 TL 20	R 2102	R 2110	102086

TUBELESS BEAD SEAL DEFINITION

The TBS is a special device allowing the fitment of tubeless tires as tubeless on tube-type rims. It consists of a ring of special rubber, which is placed inside the tire and fits between the tire beads. It ensures the airtightness of the wheel and tire assembly.

Valves and plug can be ordered separately, if required.
RANGE (for fitment with XZM TL up to and including 20")

MOUNTING INSTRUCTIONS



TUBELESS BEAD SEAL - SIZE MARKING

EXAMPLE OF MARKING:

110 TL 8 (for 4.33R - 8 rim)

110 → Width of TBS in mm

TL → Tubeless

8 → Rim diameter in inch

The choice of TBS depends on the width of the rim on which the tire is to be fitted. The allowed rim width(s) are indicated on each TBS.

3 different valves exist for TBS when only R2160 and R2102 are provided as standard with the TBS.

TBS wider than 145 mm offer two positions for the valve to accommodate the rim configuration; for those TBS, a specific plug (R2110) is provided to close the unused valve hole.

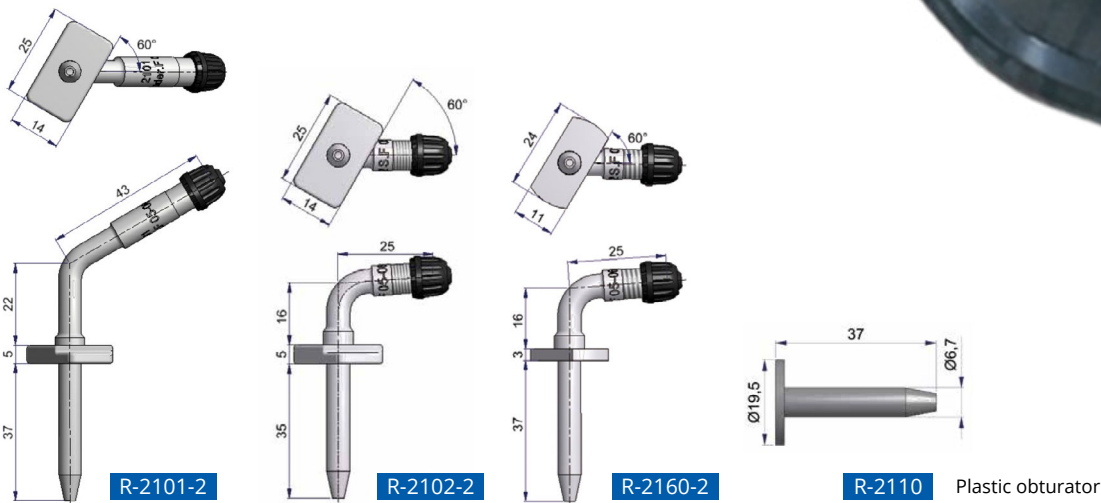

Valve holes

CROSS SECTION OF A FITTED TBS

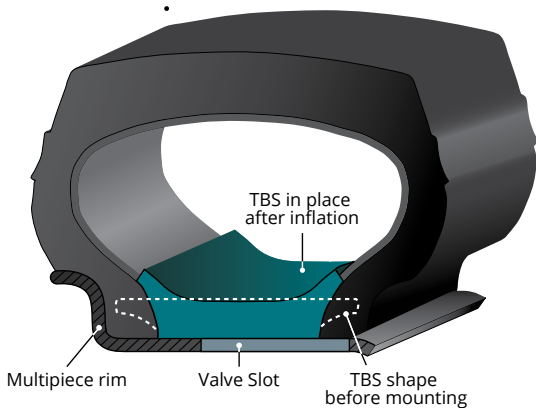

TUBETYPE SYSTEM

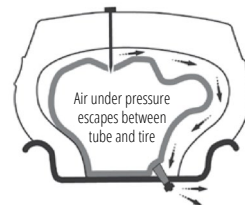

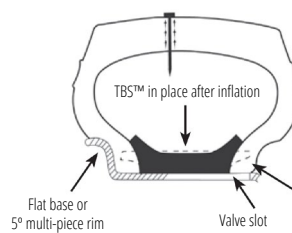

- Rapid deflations
- Risk for load or equipment damages
- Instant production stops

TUBELESS BEAD SEAL™





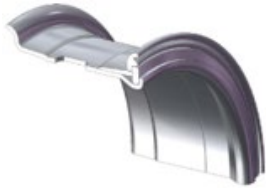

- Slower air loss delays need for immediate attention
- Equipment is still mobile and productive

APPROVED RIMS

RIM TYPES	RIM DESIGN.	A MM INCHES	G MM INCHES	RIM R/A ^(**)	TIRE SIZES	SEAL			
						TL	TT		
 <p>FLAT-BASE RIMS</p>	8 - 4.33 R	110 4.3	28,5 1.1	R	180/70R8	None			
	15 - 6.00 S	152,4 6.0	33,3 1.3	R	7.50R15				
	20 - 7.33 V	186	44	A	9.00R20 XZM	R 1443	2	2	
		7.3	1.7	A	10.00R20 XZM		2	2	
	20 - 8.00 V	203	44	A	10.00R20 XZM	Tyran	2	2	
		8.0	1.7	A	11.00R20 XZM		2	2	
	20 - 8.50 V	216	44	A	11.00R20 XZM	(A 20)	2	2	
		8.5	1.7	A	12.00R20 XZM		2	2	
	20 - 9.00 V	228,5 9.0	44	A	12.00R20 XZM		2	2	
	24 - 8.50 V	216 8.5	44	A	12.00R24 XZM	G25	2	2	
24 - 9.00 V	228,5 9.0	44	A	12.00R24 XZM	G25	2	2		
24 - 10.00 W	254 10.0	51 2.0	A	14.00R24 XZM					
 <p>5° TAPER BEAD 2-SEAT RIMS</p> <p>(removable bead seat, split)</p>	20 - B 6.5	165 6.5	38 1.5	A	9.00R20 XZM	R 1443	NA	2	
	20 - B 7.0	178	38	A	9.00R20 XZM		NA	2	
		7.0	1.5	A	10.00R20 XZM	NA	2		
	20 - B 7.5	190,5	43	A	9.00R20 XZM	Tyran	NA	2	
		7.5	1.7	A	10.00R20 XZM		NA	2	
	20 - B 8.0	203	43	A	10.00R20 XZM	(A 20)	NA	2	
		8.0	1.7	A	11.00R20 XZM		NA	2	
	20 - B 8.5	216	45,5	A	11.00R20 XZM		NA	2	
8.5		1.8	A	12.00R20	NA		2		
24 - B 8.5	216 8.5	45,5 1.8	A	12.00R24					
 <p>5° TAPER BEAD 2-SEAT RIMS (ADVANCED RIM)</p> <p>(removable bead seat, split)</p>	8 - 3.00 D	76 3.0	18 0.7	A	5.00R8	None			
	8 - 3 1/4 I (divided rim)	82,5 3.2	16 0.6	R	5.00R8				
	8 - 5.00 F	127 5.0	22,5 0.9	R	180/70R8				
	9 - 4.00 E	101,5 4.0	20 0.8	R	6.00R9				
	10 - 5.00 F	127 5.0	22,5 0.9	R	6.50R10				
	10 - 5.50 F	140 5.5	22,5 0.9	A	6.50R10				
	10 - 6.50 F	165 6.5	22,5 0.9	R	225/75R10				
	12 - 5.00 S (and divided rim)	127 5.0	31,5 1.2	R	7.00R12				
	12 - 8.00 G	203 8.0	28 1.1	R	250/75R12				
	15 - 5.5	139,5 5.5	30,5 1.2	R	7.00R15				
	15 - 6.0	152,5	33	A	7.00R15				
		6.0	1.3	R	7.50R15				
	15 - 6.5	165	35,5	A	7.50R15				
		6.5	1.4	R	8.25R15				
	15 - 7.0	178	38	R	225/75R15				
		7.0	1.5	A	8.25R15				
				A	250/70R15				
	15 - 7.5	190,5 7.5	40,5 1.6	R	250/70R15		None		
	15 - 8.0	203	43	R	315/70R15				
8,0		1.7	R	315/70R15					
15 - 9.75	247,5 9.7	38 1.5	R	355/65R15					

** R = Recommended - A = Allowed

APPROVED RIMS FOR MANUFACTURING

RIM TYPES	RIM DESIGN.	A	G	RIM R/A ^(**)	TIRE SIZES	SEAL		
		MM INCHES	MM INCHES			TL	TT	
5° TAPER BEAD 2-SEAT RIMS (ADVANCED RIM)  (removable bead seat, split)	20 - 6.5	165 6.5	35,5 1.4	A	9.00 R 20 XZM	None	NA	0
	20 - 7.0	178 7.0	38 1.5	R	9.00 R 20 XZM	None	NA	0
				A	10.00 R 20 XZM	None	NA	0
	20 - 7.0 T	177,8 7.0	38,1 1.5	R	9.00 R 20 XZM	None	NA	0
				R	10.00 R20 XZM			
	20 - 7.5	190,5 7.5	40,5 1.6	A	9.00 R 20	None	NA	0
				R	10.00 R 20	None	NA	0
				A	11.00 R 20	None	NA	0
	20 - 8.0	203 8.0	43 1.7	A	10.00 R 20	None	NA	0
				R	11.00 R 20	None	NA	0
				A	12.00 R 20	None	NA	0
	20 - 8.0 V	203 8.00	27,5 1.1	R	10.00 R 20 XZM	None	NA	2
				R	11.00 R 20	None		
	20 - 8.5	216 8.5	45,5 1.8	A	11.00 R 20 XZM	None	NA	0
R				12.00 R 20 XZM				
20 - 8.5 V	216 8.5	44,4 1.7	R	11.00 R 20	None			
			R	12.00 R 20				
20 - 9.0	228,5 9.0	48,5 1.9	A	12.00 R 20 XZM	None	NA	0	
24 - 8.5	216 8.5	45,5 1.8	A	12.00 R 24XZM	G25	NA	2	
24 - 9.0	228,5 9.0	48,5 1.9	A	12.00 R 24 XZM	G25	NA	2	
24 - 10.0	254 10.0	50,8 2.0	R	14.00 R 24 XZM	None	NA	0	
5° TAPER BEAD-SEAT RIMS (3 PIECES)  Can be Tubeless (with valve hole and O-ring) or Tube Type with valve slot. IF : Integrated Flange	24 - 10.00 WA	254 10.0	51 2.0	R	14.00 R 24 XZM	OR 3-24	1	0
				A		Sulla (OR 3-25)		
	25 - 11.25/2.0 IF ^(*)	284 11,2	51 2,0	R	16.00 R 25	Sulla (OR 3-25)		
25 - 13.00/2.5 IF ^(*)	330 13.0	63,5 2,5	R	18.00 R 25				
TAPER BEAD-SEAT RIMS (4 PIECES)  Can be Tubeless (with valve hole and O-ring) or Tube Type with valve slot	24 - 10.00 WA	254 10.0	51 2.0	R	14.00 R 24 XZM	OR 3-24		
				A		Sulla (OR 3-25)		
5° TAPER BEAD-SEAT RIMS (5 PIECES) 	25 - 11.25/2.0IN	284 11,2	51 2,0	R	16.00 R 25	Sulla (OR 3-25)		
	25 - 13.00/2.0IN	330 13.0	51 2,0	A	16.00 R 25			
	25 - 13.00/2.5IN	330 13.0	63,5 2,5	R	18.00 R 25			
				R	480/95 R 25			
	25 - 15.00/2.5IN	381 15.0	63,5 2,5	A	18.00 R 25			
33 - 13.00/2.5IN	330 13.0	63,5 2,5	R	18.00 R 33	Strix (OR 3-33)			
15° TAPER DROP-CENTER RIMS 	22.5 x 8.25	209,5 8.25	12.7 0.5	A	280/75 R 22.5 XTT	None		
				R	310/80 R 22.5 XTT (except AIM Zone)			
22.5 x 9.00	228.6 9.00	12.7 0.5	R	310/80 R 22.5				

** R = Recommended - A = Allowed

FLAP + TUBE SOLUTION



RIM & TIRE SIZE			FLAPS		TUBES			
RIM DIAM. (INCH)	RIM WIDTH (INCH)	TIRE SIZE	CAI	DESCRIPTION	CAI	DESCRIPTION	VALVE TYPE Michelin	VALVE TYPE ETRTO
8	3 1/4 I	5.00R8	894130	90 - 8	566382	8CG	570	V3-02-2
	3.00 D	5.00R8	894130	90 - 8	566382	8CG	570	V3-02-2
	3.50 D	5.00R8	894130	90 - 8	566382	8CG	570	V3-02-2
	4.33 R	150/75R8	894130	90 - 8	566382	8CG	570	V3-02-2
	4.33 R	180/70R8	894130	90 - 8	964067	8D	570	V3-02-2
9	4.00 E	6.00R9	242079	125 - 9	368957	9F	570	V3-02-2
	6.00 E	200/75R9	698290	180 - 9	368957	9F	570	V3-02-2
10	5.00 F	6.50R10	001969	140 - 10	007946	10F	1012	V3-02-23
	5.50 F	6.50R10	001969	140 - 10	007946	10F	1012	V3-02-23
	6.50 F	225/75R10	001969	140 - 10	007946	10F	1012	V3-02-23
12	5.00 S	7.00R12	190171	135 - 12	625614	12H	578	V3-04-1
	8.00 G	250/60R12	030440	210 - 12	625614	12H	578	V3-04-1
	8.00 G	250/75R12	030440	210 - 12	188148	12KD	578	V3-04-1
15	5,5	7.00R15	670236	180 - 15	812339	7.00 - 15 / 7.50 - 15	570	V3-02-2
	6,0	7.00R15	670236	180 - 15	812339	7.00 - 15 / 7.50 - 15	570	V3-02-2
	6,0	7.50R15	670236	180 - 15	812339	7.00 - 15 / 7.50 - 15	570	V3-02-2
	6,5	7.50R15	670236	180 - 15	812339	7.00 - 15 / 7.50 - 15	570	V3-02-2
	6,5	8.25R15	670236	180 - 15	694949	8.25 - 15	1188	V3-02-7
	6,5	8.25R15	670236	180 - 15	298844	8.25 - 15	1221	V3-05-1
	7,0	225/75R15	230862	180 - 15 HD	812339	7.00 - 15 / 7.50 - 15	570	V3-02-2
	7,0	250/70R15	230862	180 - 15 HD	812339	7.00 - 15 / 7.50 - 15	570	V3-02-2
	7,0	8.25R15	670236	180 - 15	694949	8.25 - 15	1188	V3-02-7
	7,0	8.25R15	670236	180 - 15	298844	8.25 - 15	1221	V3-05-1
	7,5	250/70R15	230862	180 - 15 HD	812339	7.00 - 15 / 7.50 - 15	570	V3-02-2
	8,0	315/70R15	751612	260 - 15	694949	8.25 - 15	1188	V3-02-7
9,75	355/65R15	See TBS						
20	6,5	9.00R20	907771	185 - 20	437622	8.25 - 20	1158	V3-02-14
	7,0	10.00R20	907771	185 - 20	052341	9.00 - 20	1158	V3-02-14
	7,0	9.00R20	907771	185 - 20	437622	8.25 - 20	1158	V3-02-14
	7,5	10.00R20	299014	200 - 20	052341	9.00 - 20	1158	V3-02-14
	7,5	11.00R20	299014	200 - 20	300462	10.00 - 20	1158	V3-02-14
	7,5	9.00R20	299014	200 - 20	437622	8.25 - 20	1158	V3-02-14
	8,0	10.00R20	299014	200 - 20	052341	9.00 - 20	1158	V3-02-14
	8,0	11.00R20	299014	200 - 20	300462	10.00 - 20	1158	V3-02-14
	8,0	12.00R20	299014	200 - 20	179572	11.00 - 20 / 12.00 - 20	1158	V3-02-14
	8,0	12.00R20	299014	200 - 20	024382	11.00 - 20 / 12.00 - 20	1188	V3-02-7
	8,0	12.00R20	299014	200 - 20	678384	11.00 - 20 / 12.00 - 20	1021	V3-02-10
	8,5	11.00R20	299014	200 - 20	300462	10.00 - 20	1158	V3-02-14
	8,5	12.00R20	299014	200 - 20	179572	11.00 - 20 / 12.00 - 20	1158	V3-02-14
	8,5	12.00R20	299014	200 - 20	024382	11.00 - 20 / 12.00 - 20	1188	V3-02-7
	8,5	12.00R20	299014	200 - 20	678384	11.00 - 20 / 12.00 - 20	1021	V3-02-10
	7.33 V	10.00R20	299014	200 - 20	052341	9.00 - 20	1158	V3-02-14
	7.33 V	11.00R20	299014	200 - 20	300462	10.00 - 20	1158	V3-02-14
	7.33 V	9.00R20	299014	200 - 20	437622	8.25 - 20	1158	V3-02-14
	9.00	12.00R20	299014	200 - 20	179572	11.00 - 20 / 12.00 - 20	1158	V3-02-14
	9.00	12.00R20	299014	200 - 20	024382	11.00 - 20 / 12.00 - 20	1188	V3-02-7
9.00	12.00R20	299014	200 - 20	678384	11.00 - 20 / 12.00 - 20	1021	V3-02-10	
24	8,5	12.00R24	025752	250 - 24	862045	325/95R24	582	V3-06-5
	9,0	12.00R24	025752	250 - 24	862045	325/95R24	582	V3-06-5
	10,0	14.00R24	025752	250 - 24	628804	24/25T	752	V3-02-17
	10,0	14.00R24	025752	250 - 24	734626	24/25T	1158	V3-02-14
25	11.25/2.0	16.00R25						
	11.25/2.0	450/95R25						
	13.00/2.0	16.00R25						
	13.00/2.0	450/95R25						
	13.00/2.5	18.00R25			944085	25W AM	1837	V5-04-1
	13.00/2.5	480/95R25			944085	25W AM	1837	V5-04-1
33	15.00/2.5	18.00R25			944085	25W AM	1837	V5-04-1
	13.00/2.5	18.00R33						



CORNER SEAL SOLUTION FOR SMALL INDUSTRY ON 20" RIMS

RIM Ø (INCHES)	RIM PROFILE	TIRE SIZE	DESCRIPTION	MICHELIN REF.	CAI	PACKAGING
20	7.33V - 8.00V	9.00 R 20	A 20 TYRAN	R 1443	553004	30
	8.50V - 9.00V	10.00 R 20				
	B6.5 - B7.0	11.00 R 20				
	7.0T - B7.5	12.00 R 20				
	B8.0 - 8.0V					
B8.5 - 8.5V						

O-RINGS SOLUTION

RIM Ø (INCHES)	RIM PROFILE (RECOMMENDED)	TIRE SIZE	DESCRIPTION	MICHELIN REF.	CAI	PACKAGING
24	10.00W	14.00 R 24	OR 3-25 SULLA	R1437	553200	20
	10.00WA					
10.0						
25	11.25/2.0	16.00 R 25				
	13.00/2.0	450/95 R 25				
	11.25/2.0	480/95 R 25				
	13.00/2.5	18.00 R 25				
	13.00/2.5					
	15.00/2.5					

NAME	DESIGNATION	REFERENCE	C.A.I.	TYPE	REMARKS
Tyran	A 20	R 1443	553 004	Corner seal	for 20" tires
Heupo	OR 2 - 25	R 1438	553 201	O-ring	for 25" rim (3 pieces not IF) or for 24" rim 10.00VA
Sulla	OR 3 - 25	R 1437	553 200	O-ring	for 25" rim (3 pieces IF or 5 pieces) or for 24" 10.00WA
Strix	OR 3 - 33	R 1440	553 203	O-ring	for 33" rim

SEAL DESCRIPTION

O-RING

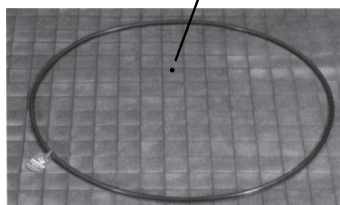

Explanation of the sealing ring designation

The first number is the section diameter of the seal:

- Or: Abbreviation of o-ring
- Imperial number: value expressed in 1/8 of inch (3 = 3/8)

- Decimal number: value expressed in mm (6.6 = 6,6 mm)

The second number is the nominal bead seat diameter, expressed in inches.

CORNER SEAL

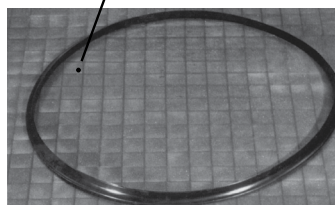

Explanation of the corner seal designation

The letter indicates the profile of the seal.

The number is the nominal rim diameter, in inches.

Note:

Approval for use of corner seals MUST BE obtained from Michelin.

VALVE AND ASSOCIATED ACCESSORIES

FOR MANUFACTURING AND WAREHOUSING TIRES AND RIMS

IN ALL CASES, THE VALVE CAP IS ESSENTIAL BECAUSE IT HELPS MAINTAIN THE CLEANLINESS OF THE MECHANISM AND ENSURE AIR TIGHTNESS OF THE VALVE.

CAR TUBE-TYPE STRAIGHT VALVE

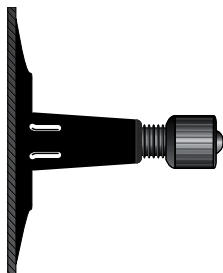

VALVE MARKINGS

The valve is circular and is marked in accordance with ETRTO standards, starting at the top of the valve, and in the following order:

- NAME (or trademark) of the valve manufacturer and his reference number
- ETRTO reference number

FITTING A UNIVERSAL VALVE ON A MICHELIN® TUBE WITH A VALVE BASE

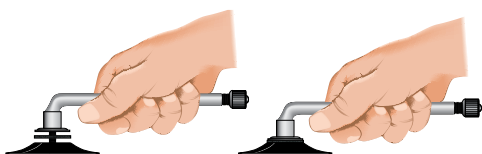

- 1 - Position the sealing ring on the valve.
The sealing ring must be clean and dry.
- 2 - Hand tighten the valve until it just touches the sealing ring.
- 3 - Tighten the valve for a further two turns.
- 4 - To orientate the valve in the desired position, tighten further.



IMPORTANT: never unscrew the valve to the desired position.

SMALL TRUCK UNIVERSAL STRAIGHT VALVE

Fitted to MICHELIN® tubes for the occasional equipment Tube-Type on 5° and 15° non-U-taper, drop center rim.

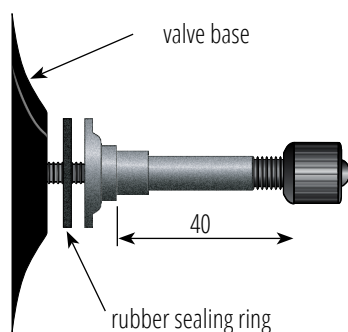

TRUCK-TYPE VALVE

TRUCK-TYPE, UNIVERSAL SINGLE-BEND VALVE

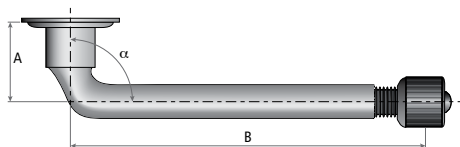

Michelin code	ETRTO Designation	A		B		α°
		mm	inches	mm	inches	
570	V3-02-2	22,5	0.89	43	1.69	120
576	V3-02-3	33	1.30	44,5	1.75	95
752	V3-02-17	20,5	0.81	156,5	6.16	90
1012	V3-02-23	30	1.18	65	2.56	90
1021	V3-02-10	20,5	0.81	115	4.53	94
1156	V3-02-9	20,5	0.81	99,5	3.92	94
1157	V3-02-12	20,5	0.81	132	5.20	94
1158	V3-02-14	20,5	0.81	138,5	5.45	94

TRUCK-TYPE, UNIVERSAL DOUBLE-BEND VALVE

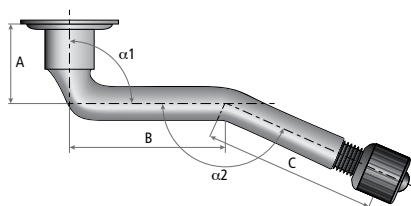

Michelin code	ETRTO Designation	α1°	α2°
578	V3-04-1	90	140

A		B		C	
mm	inches	mm	inches	mm	inches
20.5	0.81	32	1.26	37	1.46

TRUCK-TYPE, UNIVERSAL TRIPLE-BEND VALVE

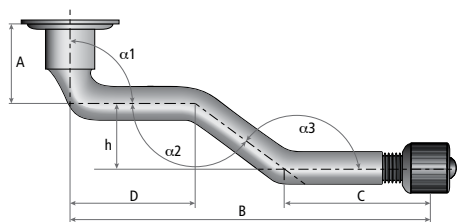

Michelin code	ETRTO Designation	α1°	α2°	α3°
582	V3-06-5	90	139	139

A		B		C		D	
mm	inches	mm	inches	mm	inches	mm	inches
20,5	0.81	131	5.16	49	1.93	62,5	2.46

TYPES OF TUBELESS EARTHMOVER VALVES

TYPE A1 VALVE

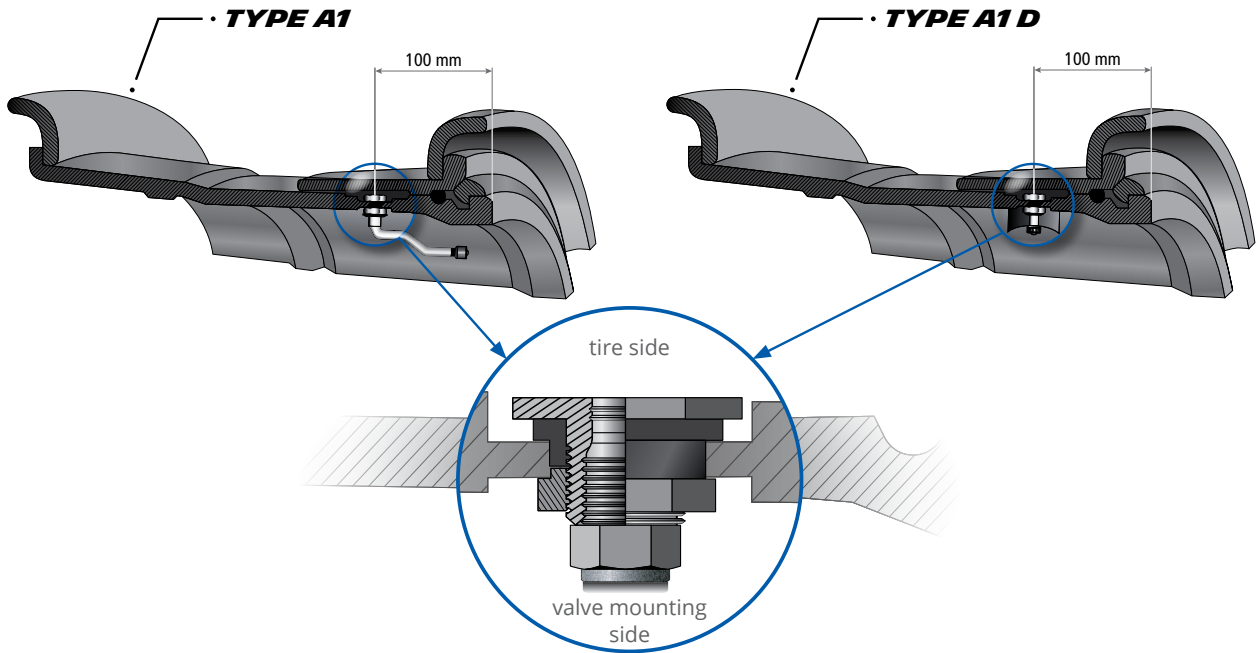

VALVE COMBINATION TYPE A4

Comprised of two TYPE A1 valves, both set at 100 mm from the rim edge, to enable water filling.

VALVE TYPE A2

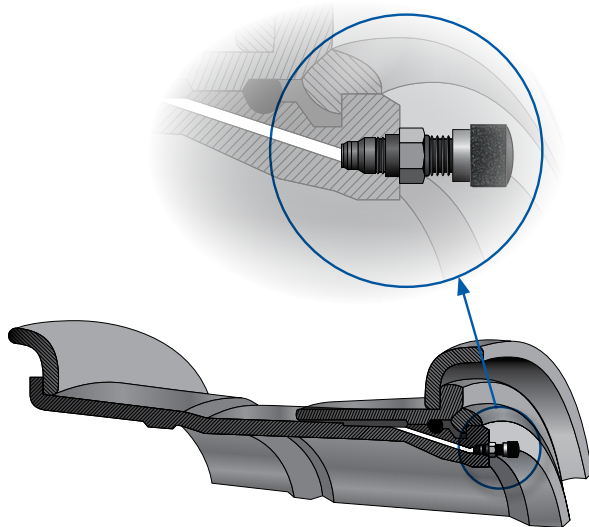

VALVE TYPE A3

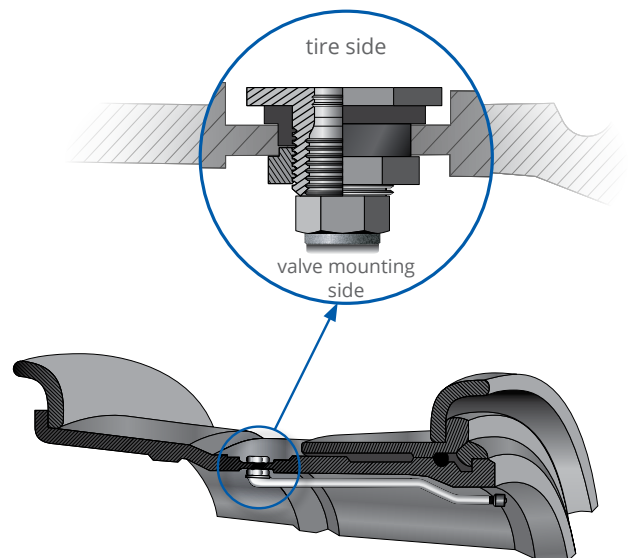

EARTHMOVER TUBELESS VALVE

(AMERICAN, TRA STANDARD)

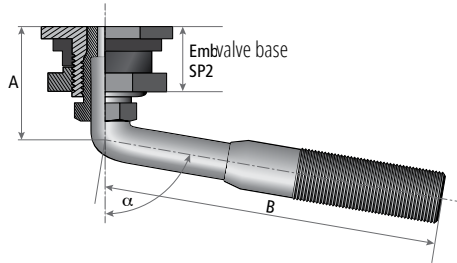

Michelin code	TRA code	ETRTO Designation	A		B		α°
			mm	inches	mm	inches	
R 1837	TRJ 650	V5-04-1	27	1.08	79	3.12	100°

Valves used on a SP2 American valve base [20.5 mm (0.8 inch) diameter hole] and also on AM tubes.

VALVE BASE

ACTUAL VALVE

(mounting with tube)

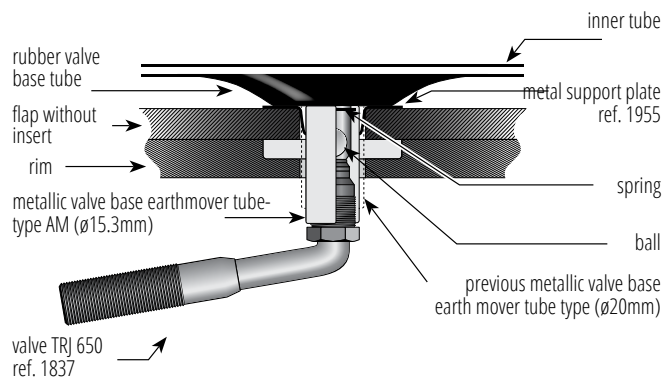

AIR AND WATER AGRICULTURAL-TYPE VALVE BASE

Allows tire to be water-filled.
Valve with core holder 1139 and plastic nut ref. 1225

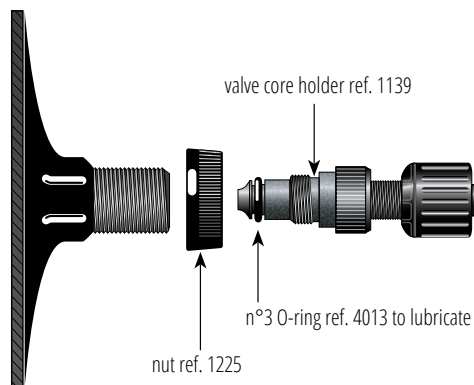

ref. 1224 code TR 218A

APPROXIMATE LOOSE MATERIAL DENSITIES

UNITS OF MEASURE AND CONVERSION TABLES

UNITS OF MEASURE AND CONVERSION TABLES

MEASUREMENT	ABBREVIATION	CONVERSION FACTOR	ABBREVIATION	MEASUREMENT	CONVERSION FACTOR	ABBREVIATION
TORQUE						
pound-foot	lb ft	x 0.1383	= m kg	kilogramme metre	x 7.233	= lb ft
kilogramme metre	m kg	x 9.81	= m N	Newton metre	x 0.102	= m kg
LENGTH						
inch	in	x 0.0254	= m	metre	x 39.37	= in
foot	ft	x 0.3048	= m	metre	x 3.281	= ft
yard	yd	x 0.9144	= m	metre	x 1.0936	= yd
mile	mi	x 1.6093	= km	kilometre	x 0.6214	= mi
LOAD						
pound	lb	x 0.4536	= kg	kilogramme	x 2.205	= lb
long ton (G.B.) 2240 lb	lg ton	x 1.016	= t	metric tonne	x 0.984	= lg ton
short ton (U.S.) 2000 lb	sh ton	x 0.907	= t	metric tonne	x 1.103	= sh ton
DENSITY						
pound per cubic foot	lb/cu ft	x 16.0184	= kg/m ³	kilogramme/m ³	x 0.625	= lb/cu ft
pound per cubic yard	lb/cu yd	x 0.5933	= kg/m ³	kilogramme/m ³	x 1.686	= lb/cu yd
PRESSURE						
kilo-pascal	kPa	x 0.01	= bar	bar	x 100	= kPa
atmosphere (at sea level)	atm	x 0.986	= bar	bar	x 1.014	= atm
pound per square inch	P.S.I.	x 0.0703	= kg/cm ²	kilogramme/cm ²	x 14.22	= P.S.I.
pound per square inch	P.S.I.	x 0.069	= bar	bar	x 14.513	= P.S.I.
pound per square inch	P.S.I.	x 0.068	= atm	atmosphere	x 14.7	= P.S.I.
pound per square inch	P.S.I.	x 6.895	= kPa	kilo Pascal	x 0.145	= P.S.I.
POWER						
french horse power	C.V.	x 0.7355	= KW	kilowatt	x 1.36	= C.V.
horse power	H.P.	x 0.7457	= KW	kilowatt	x 1.34	= H.P.
french horse power	C.V.	x 0.98	= H.P.	horse power	x 1.014	= C.V.
VOLUME/CAPACITY						
cubic foot	cu ft	x 0.02832	= m ³	cubic metre	x 35.31	= cu ft
cubic yard	cu yd	x 0.7646	= m ³	cubic metre	x 1.308	= cu yd
gallon (U.S.)	gal	x 3.7854	= l	liter	x 0.2642	= gal
TEMPERATURE						
degree fahrenheit	°F	- 32 et x (5/9)	= °C	degree Celsius	x (9/5) et + 32	= °F



2025 MATERIAL HANDLING

*INDUSTRIAL PNEUMATIC TIRES
RADIAL TECHNOLOGY*

HEADQUARTERS

Manufacture Française des Pneumatiques Michelin
partnership limited by shares with capital of 504 000 004 €
Registered office: Place des Carmes Déchaux - 63040 CLERMONT-FERRAND Cedex 9 - FRANCE
Tel.: +33(0)4 73 32 20 00

855 200 507 RCS Clermont-Ferrand